

# Recursive Circulants and their Embeddings among Hypercubes

**Jung-Heum Park**

*School of Computer Science and Engineering*

*The Catholic University of Korea*

*Yokkok 2-dong 43-1, Wonmi-gu, Puchon 420-743, Republic of Korea*

*jhpark@tcs.cuk.ac.kr*

*Tel: +82-32-340-3366*

*Fax: +82-32-340-3777*

and

**Kyung-Yong Chwa**

*Department of Computer Science*

*Korea Advanced Institute of Science and Technology*

*Kusong-dong 373-1, Yusong-gu, Taejon 305-701, Republic of Korea*

*kychwa@jupiter.kaist.ac.kr*

*Tel: +82-42-869-3513*

*Fax: +82-42-869-3510*

# Recursive Circulants and their Embeddings among Hypercubes

## Abstract

We propose an interconnection structure for multicomputer networks, called *recursive circulant*. Recursive circulant  $G(N, d)$  is defined to be a circulant graph with  $N$  nodes and jumps of powers of  $d$ .  $G(N, d)$  is node symmetric, and has some strong hamiltonian properties.  $G(N, d)$  has a recursive structure when  $N = cd^m$ ,  $1 \leq c < d$ . We develop a shortest path routing algorithm in  $G(cd^m, d)$ , and analyze various network metrics of  $G(cd^m, d)$  such as connectivity, diameter, mean internode distance, and visit ratio.  $G(2^m, 4)$ , whose degree is  $m$ , compares favorably to the hypercube  $Q_m$ .  $G(2^m, 4)$  has the maximum possible connectivity, and its diameter is  $\lceil (3m - 1)/4 \rceil$ . Recursive circulants have interesting relationship with hypercubes in terms of embedding. We present expansion one embeddings among recursive circulants and hypercubes, and analyze the costs associated with each embedding. The earlier version of this paper appeared in [21].

**Key Words:** Circulant graph, connectivity, diameter, embedding, hamiltonian property, interconnection structure, multicomputer network, routing algorithm

# 1 Introduction

Need for high computing power has continued to drive the high speed computer design. One of the most straightforward and the least expensive means of achieving this end is to construct multicomputer networks that consist of nodes with local memory (no shared memory) and a communication controller, where each node is connected by communication links to a number of other nodes [23]. Whenever a node wants to communicate with another node, it communicates through other nodes unless there exists a direct communication link between the two.

The interconnection structure for a multicomputer network plays a central role in determining the overall performance of the system [14, 23]. Since the 1960's, many authors have been concerned with the problems associated with the design and analysis of interconnection structures [1, 2, 7, 10, 21, 23]. One of the most popular interconnection structures being used is a hypercube [9, 25].

We propose an interconnection structure for multicomputer networks, called *recursive circulant*. The recursive circulant  $G(N, d)$ ,  $d \geq 2$ , is defined as follows: the node set  $V = \{0, 1, 2, \dots, N - 1\}$ , and the edge set  $E = \{(v, w) \mid \exists i, 0 \leq i \leq \lceil \log_d N \rceil - 1, \text{ such that } v + d^i \equiv w \pmod{N}\}$ . Here each  $d^i$  is called a *jump*.  $G(N, d)$  also can be defined as a circulant graph with jumps of powers of  $d$ ,  $d^0, d^1, \dots, d^{\lceil \log_d N \rceil - 1}$ . Examples of recursive circulants are shown in Figure 1.

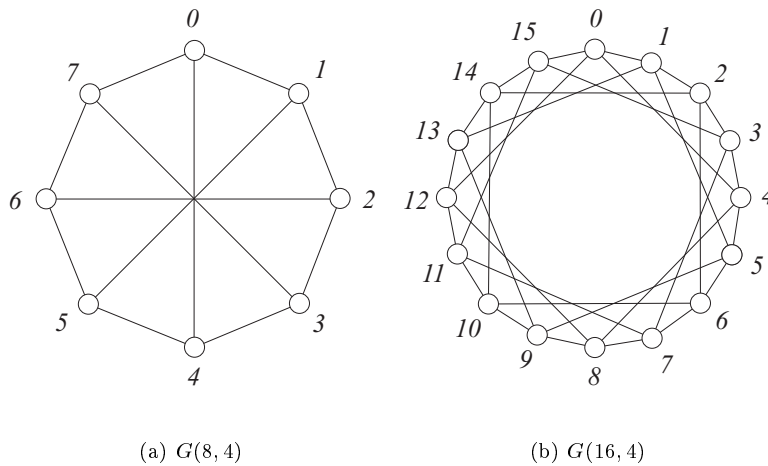

Figure 1: Examples of  $G(N, d)$

Recursive circulant is a Cayley graph over an abelian group, in more precise words, the Cayley graph of the cyclic group  $\mathbb{Z}_N$  with the generating set  $\{d^0, d^1, \dots, d^{\lceil \log_d N \rceil - 1}\}$ . Recursive circulant is node symmetric, and thus regular. Recursive circulant is not edge symmetric. For example,  $G(8, 4)$  has one cycle of length 4 passing through the edge  $(0, 1)$ , and has two distinct cycles of length 4

passing through the edge  $(0, 4)$ . However, two edges  $(v, v + d^i)$  and  $(w, w + d^i)$  are similar, that is, there is an automorphism  $g$  of  $G(N, d)$  such that  $g(v) = w$  and  $g(v + d^i) = w + d^i$ .

Recursive circulant  $G(N, d)$  has a recursive structure when  $N = cd^m$ ,  $1 \leq c < d$ . In other words,  $G(cd^m, d)$  can be defined recursively by utilizing the following property.

**Property 1** Let  $V_i$  be a subset of nodes in  $G(cd^m, d)$  such that  $V_i = \{v \mid v \equiv i \pmod{d}\}$ ,  $m \geq 1$ . For  $0 \leq i < d$ , the subgraph of  $G(cd^m, d)$  induced by  $V_i$  is isomorphic to  $G(cd^{m-1}, d)$ .

$G(cd^m, d)$ ,  $m \geq 1$ , can be defined recursively on  $d$  copies of  $G(cd^{m-1}, d)$  as follows. Let  $G_i(V_i, E_i)$ ,  $0 \leq i < d$ , be a copy of  $G(cd^{m-1}, d)$ . We assume that  $V_i = \{v_0^i, v_1^i, \dots, v_{cd^{m-1}-1}^i\}$ , and  $G_i$  is isomorphic to  $G(cd^{m-1}, d)$  for the isomorphism mapping  $v_j^i$  to  $j$  for all  $0 \leq j < cd^{m-1}$ . We relabel  $v_j^i$  by  $jd + i$ . The node set  $V$  of  $G(cd^m, d)$  is  $\bigcup_{0 \leq i < d} V_i$ , and its edge set  $E$  is  $\bigcup_{0 \leq i < d} E_i \cup X$ , where  $X = \{(v, w) \mid v + 1 \equiv w \pmod{cd^m}\}$ . The construction of  $G(32, 4)$  on four copies of  $G(8, 4)$  is illustrated in Figure 2.

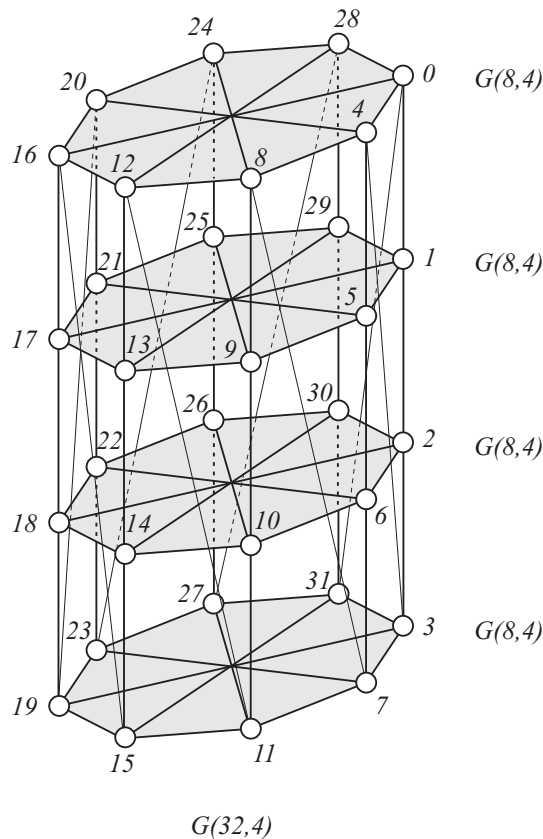

Figure 2: Construction of  $G(32, 4)$  on 4 copies of  $G(8, 4)$

When  $c \geq 3$ ,  $G(cd^0, d)$  and  $G(cd^1, d)$  are isomorphic to the cycle graph of length  $c$  and the  $c \times d$

double loop network, respectively. We denote by  $\delta_m$  the degree of  $G(cd^m, d)$ . Then,  $\delta_m = \delta_{m-1} + 2$ ,  $m \geq 1$ .  $\delta_m$  in a closed-form is shown below:

$$\delta_m = \begin{cases} 2m - 1 & \text{if } c = 1 \text{ and } d = 2; \\ 2m & \text{if } c = 1 \text{ and } d \neq 2; \\ 2m + 1 & \text{if } c = 2; \\ 2m + 2 & \text{if } c > 2. \end{cases}$$

Depending on the restriction on  $N$  and  $d$ , we have interesting classes of recursive circulants. Their inclusion relationships are shown in Figure 3. Among them,  $G(2^m, 2)$  is a supergraph of an  $m$ -dimensional hypercube  $Q_m$ , and  $G(2^m, 4)$  has the same number of nodes and edges as  $Q_m$ .  $G(2^m, 4)$  with  $m \geq 3$  is not isomorphic to  $Q_m$  since  $G(2^m, 4)$  has a cycle of odd length. In fact,  $G(2^m, 2^k)$  with  $2 \leq k < m$  is known to be a tripartite graph.

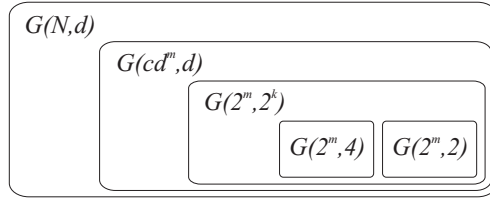

Figure 3: Classes of recursive circulants

Recursive circulants have some interesting hamiltonian properties. Obviously,  $G(N, d)$  has a hamiltonian cycle unless  $N \leq 2$ . Recursive circulant  $G(cd^m, d)$  is hamiltonian decomposable [11, 19, 20], that is,  $G(cd^m, d)$  has  $\lfloor \delta_m/2 \rfloor$  edge-disjoint hamiltonian cycles. Hamiltonian decomposability of  $G(N, d)$  remains open. In Section 2 of this paper, we show that  $G(N, d)$  with degree three or more is either hamiltonian connected or bipartite and bihamiltonian connected.

Network metrics provide a framework for comparing various networks systematically. They include not only node symmetry, edge symmetry, and hamiltonian property, but also connectivity, diameter, mean internode distance, and visit ratio. We develop a shortest path routing algorithm in  $G(cd^m, d)$  in Section 3, and analyze network metrics of  $G(cd^m, d)$  in Section 4.

Compared with  $Q_m$ ,  $G(2^m, 4)$  achieves noticeable improvements in diameter, mean internode distance, and node visit ratio. The diameter, mean internode distance, and node visit ratio of  $G(2^m, 4)$  are  $\lceil (3m - 1)/4 \rceil$ , approximately  $(9/20)m$ , and approximately  $((9/20)m + 1)/2^m$ , while those of  $Q_m$  are  $m$ , approximately  $(1/2)m$ , and approximately  $((1/2)m + 1)/2^m$ , respectively.

The connectivity and edge connectivity of  $G(2^m, 4)$  are  $m$ , which is the best possible. The edge visit ratio of  $G(2^m, 4)$  is  $1/(2^m - 1)$ , which is equal to that of  $Q_m$ .  $G(2^m, 4)$  has a simple shortest path routing algorithm without routing table and a simple recursive broadcasting algorithm [21]. Moreover,

$G(2^m, 4)$  is known to be a minimum broadcast (and gossip) graph, that is,  $G(2^m, 4)$  is a graph with the minimum number of edges such that a broadcast (and gossip) from any node can be performed in minimum time.

Understanding relationships among different interconnection structures plays an important role in parallel processing [8, 24]. We investigate relationships among recursive circulants and hypercubes in terms of embedding. Many problems of interest can be modeled by embedding such as VLSI circuit layout, simulating one interconnection structure by another, and simulating one data structure by another [3].

$G(2^m, 4)$  contains as subgraphs cycles of any length strictly greater than three, binomial trees with  $2^m$  nodes, and full binary trees with no more than  $2^m$  nodes [18]. Pyramid of level  $m$  is known to be embedded into recursive circulant  $G(2^{2m-1}, 4)$  with dilation two, congestion two, and the optimal expansion [17]. Many of the embedding problems into recursive circulants remain unsolved.

In Section 5, we present expansion one embeddings among recursive circulants  $G(2^m, 2^k)$  and hypercubes  $Q_m$ . The embedding of  $G(2^m, 2^k)$  into  $Q_m$  is based on the binary reflected Gray code and has dilation two and congestion four. The dilation is the best possible when  $k < m$ . For the reverse, we can always embed  $Q_m$  into  $G(2^m, 2^k)$  with the same embedding costs as the embedding of  $Q_k$  into a path graph with  $2^k$  vertices. Embedding of a graph into a path graph is known as a linear arrangement. Employing the linear arrangements of hypercubes [12, 13], we can achieve embeddings of  $Q_m$  into  $G(2^m, 2^k)$  with either dilation  $2^{k-1}$  and congestion  $\lfloor 2^{k+1}/3 \rfloor$  or dilation  $\sum_{i=0}^{k-1} \binom{i}{\lfloor i/2 \rfloor}$  and congestion  $\lceil \frac{k}{2} \rceil \binom{k}{\lfloor k/2 \rfloor}$ .

## 2 Hamiltonian property of $G(N, d)$

A graph is *hamiltonian connected* if there is a hamiltonian path joining every pair of vertices. Hamiltonian connectedness as well as hamiltonian decomposition is an interesting strong hamiltonicity, that is, a hamiltonian property which implies the existence of a hamiltonian cycle. Necessarily, a hamiltonian connected graph is not bipartite. In this section, we show that recursive circulant  $G(N, d)$  with degree three or more is either hamiltonian connected or bipartite and bihamiltonian connected. A bipartite graph is *bihamiltonian connected* if between every pair of vertices with colors different from each other, there is a hamiltonian path. Each vertex in a bipartite graph has one of two colors, say red and blue, in such a way that no two adjacent vertices are of the same color.

We employ a theorem in [6] on hamiltonian connectedness of a Cayley graph over an abelian group.

**Theorem 1** *A Cayley graph over a finite abelian group is hamiltonian connected if and only if it is neither a cycle graph nor a bipartite graph.*

**Corollary 1** *Every recursive circulant  $G(N, d)$  with degree three or more is hamiltonian connected if it is not bipartite.*

Now, let us concentrate on bipartite recursive circulant  $G(N, d)$ .

**Lemma 1**  *$G(N, d)$  with degree three or more is bipartite if and only if  $N$  is even and  $d$  is odd.*

*Proof*  $G(N, d)$  has a hamiltonian cycle of length  $N$ , and has a cycle  $(0, 1, \dots, d)$  of length  $d + 1$ . Thus, we have the necessity. For the sufficiency, we observe that every jump  $d^i$  (including jump  $d^0$ ) in  $G(N, d)$  joins a pair of an even vertex and an odd vertex. This completes the proof.  $\square$

Again, we employ a lemma in [6]. A  $p \times q$  rectangular grid is a product of two path graphs with  $p$  and  $q$  vertices, respectively. A rectangular grid is bipartite. We call a vertex in a rectangular grid a *corner vertex* if it is of degree two.

**Lemma 2** *Let  $G$  be a  $p \times q$  rectangular grid with  $p, q \geq 2$ .*

(a) *If  $pq$  is even, then  $G$  has a hamiltonian path from any corner vertex  $v$  to any other vertex with color different from  $v$ .*

(b) *If  $pq$  is odd, then  $G$  has a hamiltonian path from any corner vertex  $v$  to any other vertex with the same color as  $v$ .*

**Theorem 2** *Every bipartite recursive circulant  $G(N, d)$  with degree three or more is bihamiltonian connected.*

*Proof* A circulant graph  $C_N(1, d)$ , the Cayley graph of a cyclic group  $\mathbb{Z}_N$  with the generating set  $\{1, d\}$ , is a spanning subgraph of  $G(N, d)$ . We are sufficient to show that  $C_N(1, d)$  with  $N$  even and  $d$  odd ( $d \neq 1, N - 1$ ) is bihamiltonian connected. We can assume that  $d \leq N/2$  since  $C_N(1, d)$  is isomorphic to  $C_N(1, N - d)$ . We let  $n = \lfloor N/d \rfloor$  and  $d' = N \bmod d$ , that is,  $N = nd + d'$ ,  $0 \leq d' < d$ . We have that  $d \geq 3$  by Lemma 1 and  $n \geq 2$ . A spanning subgraph of  $C_N(1, d)$  is shown in Figure 4 depending on the parity of  $n$ . We denote by  $G'$  the subgraph of  $C_N(1, d)$  induced by vertices  $\{0, 1, 2, \dots, nd - 1\}$ .  $G'$  contains a  $d \times n$  rectangular grid as a spanning subgraph. It is sufficient to show that  $C_N(1, d)$  has a hamiltonian path joining an odd vertex  $N - 1$  and every even vertex since  $C_N(1, d)$  is node symmetric.

*Case 1*  $n$  is even.

When  $d' = 0$ ,  $N - 1$  is a corner vertex of  $G'$ , and thus, by Lemma 2 (a), there is a hamiltonian path joining  $N - 1$  and every even vertex. We let  $d' > 0$ . Note that  $nd$  is even and  $(n - 1)d$  is an odd corner vertex. For even vertex  $v$  such that  $v < nd$ , we construct a hamiltonian path  $P = N - 1, N - 2, \dots, nd, (n - 1)d, P_1, v$ , where  $P_1$  is a hamiltonian path in  $G'$  joining  $(n - 1)d$  and  $v$  due to Lemma 2 (a). For  $v$  such that  $v \geq nd$ , we have a hamiltonian path  $P = N - 1, N - 2, \dots, v +$

$1, v-d+1, P_2, (n-1)d, nd, nd+1, \dots, v$ , where  $P_2$  is a hamiltonian path in  $G'$  between  $v-d+1$  and  $(n-1)d$ .

*Case 2*  $n$  is odd.

In this case,  $nd$  is odd and  $(n-1)d$  is an even corner vertex. For an even vertex  $v$  such that  $v < nd$  and  $v \neq (n-1)d$ , we construct a hamiltonian path  $P = N-1, N-2, \dots, nd, (n-1)d, P_3, v$ , where  $P_3$  is a hamiltonian path in  $G'$  joining  $(n-1)d$  and  $v$  due to Lemma 2 (b). For  $v = (n-1)d$ , we utilize another even corner vertex  $nd-1$  and construct a hamiltonian path  $P = N-1, N-2, \dots, nd, nd-1, P_4, (n-1)d$ , where  $P_4$  is a hamiltonian path in  $G'$  between  $nd-1$  and  $(n-1)d$ . For  $v \geq nd$ , there is a hamiltonian path  $P = N-1, N-2, \dots, v+1, v-d+1, P_5, (n-1)d, nd, nd+1, \dots, v$ , where  $P_5$  is a hamiltonian path in  $G'$  between  $v-d+1$  and  $(n-1)d$ . This completes the proof.  $\square$

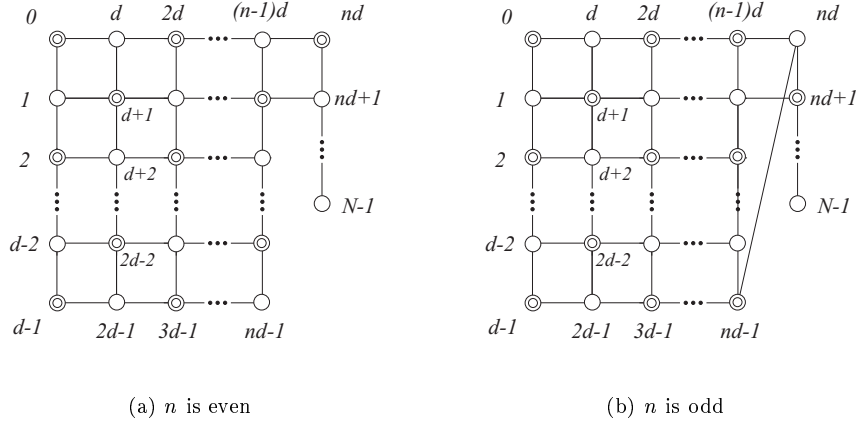

Figure 4: Illustration of the proof of Theorem 2

### 3 Routing algorithm in $G(cd^m, d)$

In this section, we develop a shortest path routing algorithm in  $G(cd^m, d)$ . From now on, all arithmetics are done modulo  $cd^m$  using the appropriate residues. We describe our routing algorithm briefly as follows. When a node  $v$  of  $G(cd^m, d)$  has a message to  $w$ ,  $v$  sends it along edges of jump  $d^0$  to one of the two nodes  $x$  and  $y$  such that  $x \equiv y \equiv w \pmod{d}$ ,  $x < v < y$ ,  $v-x < d$ , and  $y-v < d$ , if  $v \not\equiv w \pmod{d}$ ; otherwise,  $v$  does nothing. Then routing in the subgraph of  $G(cd^m, d)$  induced by  $V_w = \{z \mid z \equiv w \pmod{d}\}$  is performed recursively. Note that the induced subgraph is isomorphic to  $G(cd^{m-1}, d)$ . The routing algorithm is based on the properties of a shortest path from node 0 to node  $v$ .

A path from node 0 to node  $v$  is a sequence of nodes  $v_0 = 0, v_1, v_2, \dots, v_t = v$ . It also can be



represented by  $a_1, a_2, \dots, a_t$ , where  $a_i = v_i - v_{i-1}$ ,  $1 \leq i \leq t$ . The  $i$ th node  $v_i$  is  $\sum_{1 \leq j \leq i} a_j$ . Here  $a_i$  is either  $+d^j$  or  $-d^j$  for some  $j$ , that is, a jump with direction either  $+$  or  $-$ . For example, the path  $0, 4, 5, 6, 10, 9, 8$  of  $G(16, 4)$  in Figure 1 (b) can be represented by  $+4, +1, +1, +4, -1, -1$ . We will represent a path from node 0 by a sequence of jumps with directions. The destination node  $v$  of a path  $P = a_1, a_2, \dots, a_t$ , from node 0 is  $\sum_{1 \leq j \leq t} a_j$ . Note that an arbitrary permutation of  $P$  represents a path (may have a cycle) to the same destination of the same length.

**Lemma 3** *Let  $P = a_1, a_2, \dots, a_t$ , be a shortest path from 0 to  $v$ .*

(a)  *$P$  has no pair of  $+d^j$  and  $-d^j$  for any  $j$ .*

(b)  *$P$  has less than  $d$  “ $+d^j$ ’s” and has less than  $d$  “ $-d^j$ ’s” for any  $j$ .*

*Proof* Suppose  $P$  has a pair of  $+d^j$  and  $-d^j$  for some  $j$ , we can construct another path  $P'$  from 0 to  $v$  shorter than  $P$  by removing the pair of  $+d^j$  and  $-d^j$  in  $P$ . This is contradiction to the fact that  $P$  is a shortest path. Suppose  $P$  has  $d$  or more “ $+d^j$ ’s” (resp. “ $-d^j$ ’s”). The  $d$  “ $+d^j$ ’s” (resp. “ $-d^j$ ’s”) can be replaced by one “ $+d^{j+1}$ ” (resp. “ $-d^{j+1}$ ”), resulting in a path shorter than  $P$  by  $d - 1$ , if  $+d^j$  is not a jump of maximum size. If  $+d^j$  is a jump of maximum size, the sum of  $d$  or less ( $d$  if  $c = 1$ ,  $c$  otherwise)  $+d^j$ ’s (resp.  $-d^j$ ’s) is zero, thus they can be removed to get a shorter path than  $P$ . This completes the proof.  $\square$

A node  $v$  is called a *town* if  $v$  is a multiple of  $d$ ; otherwise,  $v$  is called a *village*. For a village  $v$ , there exists a unique  $i$  such that  $di < v < d(i + 1)$ . Here,  $di$  and  $d(i + 1)$  are called *near towns* of  $v$ . Every village has two near towns.

**Lemma 4** (a) *No shortest path from 0 to a town passes through villages.*

(b) *There is a shortest path from 0 to a village  $v$  passing through one of the near towns of  $v$ .*

*Proof* Let  $P = a_1, a_2, \dots, a_t$ , be a shortest path from 0 to  $v$ . To prove (a), we assume that  $v$  is a town. Suppose  $P$  passes through some villages, then  $P$  has either  $+d^0$  or  $-d^0$ . By Lemma 3 (a) and (b),  $v = \sum_{1 \leq i \leq t} a_i \not\equiv 0 \pmod{d}$ , which is a contradiction to the fact that  $v$  is a town. To prove (b), we assume that  $v$  is a village such that  $di < v < d(i + 1)$  for some  $i$ . By Lemma 3 (a) and (b), we can see that  $P$  has either  $v - di$  “ $+d^0$ ’s” or  $d(i + 1) - v$  “ $-d^0$ ’s”. When  $P$  has  $v - di$  “ $+d^0$ ’s”, we let  $P' = a'_1, a'_2, \dots, a'_t$  be a permutation of  $P$  such that  $a'_j = +d^0$  for all  $j$ ,  $t - (v - di) < j \leq t$ .  $P'$  is a shortest path from 0 to  $v$ , and passes through  $di$  since  $\sum_{1 \leq j \leq t - (v - di)} a'_j = di$ . When  $P$  has  $d(i + 1) - v$  “ $-d^0$ ’s”, in a similar way, we let  $P'' = a''_1, a''_2, \dots, a''_t$  be a permutation of  $P$  such that  $a''_j = -d^0$  for all  $j$ ,  $t - (d(i + 1) - v) < j \leq t$ .  $P''$  is a shortest path from 0 to  $v$  passing through  $d(i + 1)$ . This completes the proof.  $\square$

Lemma 4 (a) implies that a shortest path from 0 to a town can be found in the subgraph of  $G(cd^m, d)$  induced by all towns. Note that the subgraph induced by all towns is isomorphic to  $G(cd^{m-1}, d)$  by Property 1. We denote by  $dist_m(v)$  the length of a shortest path from 0 to  $v$  in

$G(cd^m, d)$ . The length of a shortest path from 0 to a village  $v$  such that  $di < v < d(i+1)$  is, by Lemma 4 (b),  $\min\{(v - di) + \text{dist}_m(di), (d(i+1) - v) + \text{dist}_m(d(i+1))\}$ . Observe that  $\text{dist}_m(di) = \text{dist}_{m-1}(i)$  and  $\text{dist}_m(d(i+1)) = \text{dist}_{m-1}(i+1)$ .

A near town  $di$  (resp.  $d(i+1)$ ) of  $v$  is called the *nearest town* of  $v$  if  $v - di < d(i+1) - v$  (resp.  $d(i+1) - v < v - di$ ). When  $d$  is odd, every village has a unique nearest town. When  $d$  is even, every village other than  $di + d/2$  has a nearest town; the node  $di + d/2$  has no nearest town.

**Lemma 5** *If a village  $v$  has a nearest town, there is a shortest path from 0 to  $v$  passing through the nearest town.*

*Proof* If  $di$  is the nearest town, we have  $\text{dist}_m(v) = \min\{(v - di) + \text{dist}_m(di), (d(i+1) - v) + \text{dist}_m(d(i+1))\} = (v - di) + \text{dist}_m(di)$ . Note that the difference between  $\text{dist}_m(di)$  and  $\text{dist}_m(d(i+1))$  is at most 1 since  $di$  and  $d(i+1)$  are adjacent. If  $d(i+1)$  is the nearest town, we can see that  $\text{dist}_m(v) = (d(i+1) - v) + \text{dist}_m(d(i+1))$ . Thus, we have the lemma.  $\square$

**Lemma 6** (a) *For odd  $d$ ,  $\text{dist}_m(di) < \text{dist}_m(di+1) < \dots < \text{dist}_m(di + \lfloor d/2 \rfloor)$ , and  $\text{dist}_m(di + \lfloor d/2 \rfloor) > \text{dist}_m(di + (\lfloor d/2 \rfloor + 1)) > \dots > \text{dist}_m(di + d)$ .*

(b) *For even  $d$ ,  $\text{dist}_m(di) < \text{dist}_m(di+1) < \dots < \text{dist}_m(di + (d/2 - 1)) \leq \text{dist}_m(di + d/2)$ , and  $\text{dist}_m(di + d/2) \geq \text{dist}_m(di + (d/2 + 1)) > \text{dist}_m(di + (d/2 + 2)) > \dots > \text{dist}_m(di + d)$ .*

*Proof* It is sufficient to show, by Lemmas 3 and 5, that the two inequalities  $\text{dist}_m(di + (d/2 - 1)) \leq \text{dist}_m(di + d/2)$  and  $\text{dist}_m(di + d/2) \geq \text{dist}_m(di + (d/2 + 1))$  hold for even  $d$ . For the first inequality, by Lemmas 3, 4, and 5, we have  $\text{dist}_m(di + d/2) = d/2 + \min\{\text{dist}_m(di), \text{dist}_m(d(i+1))\} \geq d/2 + (\text{dist}_m(di) - 1) = (d/2 - 1) + \text{dist}_m(di) = \text{dist}_m(di + (d/2 - 1))$ . We show the other inequality in a similar way that  $\text{dist}_m(di + d/2) \geq d/2 + (\text{dist}_m(d(i+1)) - 1) = (d/2 - 1) + \text{dist}_m(d(i+1)) = d(i+1) - (di + (d/2 + 1)) + \text{dist}_m(d(i+1)) = \text{dist}_m(di + (d/2 + 1))$ . Thus, we have the lemma.  $\square$

For a village  $v$  without a nearest town ( $d$  is even and  $v = di + d/2$ ), we know that there is a shortest path from 0 to  $v$  passing through  $di$  if  $\text{dist}_m(di) \leq \text{dist}_m(d(i+1))$  and one passing through  $d(i+1)$  if  $\text{dist}_m(d(i+1)) \leq \text{dist}_m(di)$ . Let us consider the question of determining whether  $\text{dist}_m(di) \leq \text{dist}_m(d(i+1))$  or  $\text{dist}_m(d(i+1)) \leq \text{dist}_m(di)$ . Since  $\text{dist}_m(di) = \text{dist}_{m-1}(i)$  and  $\text{dist}_m(d(i+1)) = \text{dist}_{m-1}(i+1)$ , it is sufficient to determine whether  $\text{dist}_{m-1}(i) \leq \text{dist}_{m-1}(i+1)$  or  $\text{dist}_{m-1}(i+1) \leq \text{dist}_{m-1}(i)$ . A simple solution for our question is given in the following lemma.

**Lemma 7** *Let  $d$  be even.*

(a) *When  $m = 1$ ,  $\text{dist}_{m-1}(i) \leq \text{dist}_{m-1}(i+1)$  if  $i < c/2$ ; otherwise,  $\text{dist}_{m-1}(i+1) \leq \text{dist}_{m-1}(i)$ .*

(b) *When  $m \geq 2$ ,  $\text{dist}_{m-1}(i) \leq \text{dist}_{m-1}(i+1)$  if  $i \pmod{d} < d/2$ ; otherwise,  $\text{dist}_{m-1}(i+1) \leq \text{dist}_{m-1}(i)$ .*

*Proof* When  $m = 1$ , the subgraph of  $G(cd^1, d)$  induced by the towns is a cycle of length  $c$  (degenerated or not). For the case where  $i < c/2$  (or equivalently  $i \leq (c-1)/2$ ),  $dist_{m-1}(i+1) = \min\{i+1, c-(i+1)\} = (c-1)/2$  if  $i = (c-1)/2$ ; otherwise (or equivalently  $i \leq c/2-1$ ),  $dist_{m-1}(i+1) = i+1$ . Thus, we have  $dist_{m-1}(i+1) \geq i = dist_{m-1}(i)$ . For the other case where  $i \geq c/2$ ,  $dist_{m-1}(i+1) = c-(i+1)$ , which is less than  $dist_{m-1}(i) = c-i$ . This proves (a). When  $m \geq 2$ , there exists  $i'$  such that  $di' \leq i < d(i'+1)$ . Now  $di'$  and  $d(i'+1)$  are towns in  $G(cd^{m-1}, d)$ . The statement (b) is immediate from Lemma 6 (b), which says that  $dist_{m-1}(di') < dist_{m-1}(di'+1) < \dots < dist_{m-1}(di'+(d/2-1)) \leq dist_{m-1}(di'+d/2)$ , and that  $dist_{m-1}(di'+d/2) \geq dist_{m-1}(di'+(d/2+1)) > dist_{m-1}(di'+(d/2+2)) > \dots > dist_{m-1}(di'+d)$ .  $\square$

Now, we are ready to give our routing algorithm in  $G(cd^m, d)$ . A message in a node  $v$  of  $G(cd^m, d)$  to node 0 is delivered along a shortest path from 0 to  $v$  in a reverse order. When  $v$  is a village of  $G(cd^m, d)$ ,  $v$  sends it to one of the near towns of  $v$  via edges of either a jump  $+d^0$  or  $-d^0$ . Between the near towns,  $v$  prefers the nearest town, if any; otherwise,  $v$  chooses one according to Lemma 7. When  $v$  is a town,  $v$  does nothing. Then, routing in  $G(cd^{m-1}, d)$  is performed recursively. For the base case of  $m = 0$ , routing in  $G(cd^0, d)$  is performed according to the following lemma.

**Lemma 8** *For  $v$  in  $G(cd^0, d)$ ,  $dist_0(v) \leq dist_0(v+1)$  if  $v < c/2$ ; otherwise,  $dist_0(v+1) \leq dist_0(v)$ .*

*Proof* The lemma is a restatement of Lemma 7 (a).  $\square$

The routing from  $v$  to  $w$  can be achieved easily from the routing from  $v-w$  to 0, since a shortest path from  $v$  to  $w$  when it is represented by a sequence of jumps with directions is a shortest path from  $v-w$  to 0. The routing algorithm in  $G(cd^m, d)$  shown below sends a message in a current node to one of its neighbor nodes. Repeating this process, the message eventually reaches the destination. We denote by  $v$  and  $w$  the current and destination node, respectively. We assume that  $v$  is different from  $w$ .

**Theorem 3** *The shortest path routing algorithm in  $G(cd^m, d)$  is correct.*

*Proof* The algorithm is performed on  $G(cd^{m-r}, d)$ , the subgraph of  $G(cd^m, d)$  induced by all multiple of  $d^r$  nodes. Let  $v''$  be  $b_m \dots b_{r+1}b_r$  in the  $d$ -ary number representation. Now  $v''$  is a village of  $G(cd^{m-r}, d)$ . When  $r = m$ , routing is performed according to Lemma 8. When  $r < m$ ,  $v''$  finds its nearest town, if any. If  $v''$  has no nearest town,  $v''$  chooses one between its near towns  $di$  and  $d(i+1)$  according to Lemma 7. Note that the  $d$ -ary representation of  $di$  is  $b_m \dots b_{r+1}0$ , and that  $b_{r+1} = i$  for  $r = m-1$ , and  $b_{r+1} = i \pmod{d}$  for  $r < m-1$ . The theorem is immediate from Lemmas 3, 4, 5, 6, 7, and 8.  $\square$

---

**Shortest Path Routing Algorithm in  $G(cd^m, d)$** 

```
 $v' := (v - w) \bmod cd^m;$ 
Let  $b_m \cdots b_1 b_0$  be the  $d$ -ary number representation of  $v'$ ;
 $r :=$  the least significant non-zero digit number of  $v'$ ;
/* Now, we perform routing in  $G(cd^{m-r}, d)$  */
if  $r < m$  then /*  $r$  is not the most significant digit number */
    case  $b_r$  of
         $b_r < d/2$  : forward the message to  $v - d^r$ ; /* by Lemmas 5 and 6 */
         $b_r > d/2$  : forward the message to  $v + d^r$ ; /* by Lemmas 5 and 6 */
         $b_r = d/2$  : /*  $d$  even */
            if  $r = m - 1$  then /* by Lemma 7 (a) */
                if  $b_{r+1} < c/2$  then forward the message to  $v - d^r$ 
                else forward the message to  $v + d^r$ ;
            else /* by Lemma 7 (b) */
                if  $b_{r+1} < d/2$  then forward the message to  $v - d^r$ 
                else forward the message to  $v + d^r$ ;
    end;
else /*  $r = m$  and  $c \neq 1$ ; by Lemma 8 */
    if  $b_m < c/2$  then forward the message to  $v - d^r$ 
    else forward the message to  $v + d^r$ ;
```

---

## 4 Network metrics of $G(cd^m, d)$

### 4.1 Connectivity and edge connectivity

Connectivity measures the resiliency of a network and its ability to continue operation despite faulty nodes and communication links. Connectivity (resp. edge-connectivity) is the minimum number of nodes (resp. communication links) that must fail to partition the network into two or more disjoint subnetworks. We denote by  $\kappa(G)$  and  $\lambda(G)$  the connectivity and edge-connectivity of a graph  $G$ , respectively. It holds that  $\kappa(G) \leq \lambda(G) \leq \delta(G)$  for every graph  $G$ .

By employing a sufficient condition in [5] for a circulant graph to have the maximum possible connectivity, we can show that  $\kappa_m = \lambda_m = \delta_m$ , where  $\kappa_m$  and  $\lambda_m$  are the connectivity and edge connectivity of  $G(cd^m, d)$ , respectively.

**Theorem 4** *A circulant graph  $G$  with  $n$  nodes and  $k$  jumps  $a_1, a_2, \dots, a_k$  such that  $a_1 < a_2 < \dots < a_k \leq n/2$  has  $\kappa(G) = \delta(G)$  if  $a_1 = 1$  and  $a_{i+1} - a_i \leq a_{i+2} - a_{i+1}$  for all  $i, 1 \leq i \leq k - 2$ .*

**Corollary 2**  $\kappa_m = \lambda_m = \delta_m$ .

Connectivity problems of recursive circulants were considered in [15]. It was shown that  $G(N, d)$  also has the maximum possible connectivity, and that  $G(cd^m, d)$  is super- $\kappa$  and super- $\lambda$  if it is not isomorphic to  $C_n$ , a cycle graph of length  $n$ . Here, a graph  $G$  is called super- $\kappa$  if every vertex cut of

size  $\kappa(G)$  is the set of vertices adjacent to a single vertex. A graph is super- $\lambda$  if every edge cut of size  $\lambda(G)$  is the set of edges incident to a single vertex.

## 4.2 Diameter

The diameter of a network is the maximum number of communication links that must be traversed to transmit a message from a node to another node along a shortest path between them. Since  $G(cd^m, d)$  is node symmetric, the diameter  $dia_m$  of  $G(cd^m, d)$  is the maximum of  $dist_m(v)$  over all nodes  $v$ , that is,  $dia_m = \max_{0 \leq v < cd^m} \{dist_m(v)\}$ . We know that  $dia_0 = \lfloor c/2 \rfloor$ . For  $m \geq 1$ ,  $v$  can be rewritten as  $di + j$  for some  $i$  and  $j$ ,  $0 \leq i < cd^{m-1}$ ,  $0 \leq j < d$ . Thus, we have that  $dia_m = \max_{0 \leq i < cd^{m-1}} \max_{0 \leq j < d} \{dist_m(di + j)\}$ . We let  $T_i = \max_{0 \leq j < d} \{dist_m(di + j)\}$ . To calculate  $T_i$ , we employ Lemma 6. There are two cases depending on the parity of  $d$ .

*CASE A*  $d$  is odd.

We have that  $T_i = \max\{dist_m(di + \lfloor d/2 \rfloor), dist_m(di + \lceil d/2 \rceil)\}$  by Lemma 6 (a). It holds that  $dist_m(di + \lfloor d/2 \rfloor) = dist_m(di) + \lfloor d/2 \rfloor$  and  $dist_m(di + \lceil d/2 \rceil) = dist_m(d(i+1)) + \lfloor d/2 \rfloor$  by Lemma 5. Combining them with  $dist_m(di) = dist_{m-1}(i)$  and  $dist_m(d(i+1)) = dist_{m-1}(i+1)$ , we have that  $T_i = \max\{dist_{m-1}(i), dist_{m-1}(i+1)\} + \lfloor d/2 \rfloor$ . Thus, we have that  $dia_m = \max_{0 \leq i < cd^{m-1}} T_i = \max_{0 \leq i < cd^{m-1}} \{\max\{dist_{m-1}(i), dist_{m-1}(i+1)\} + \lfloor d/2 \rfloor\}$ . The max-of-max term in the equation is equal to  $\max_{0 \leq i < cd^{m-1}} \{dist_{m-1}(i)\}$ , which is equal to  $dia_{m-1}$ . At last we get a recursive formula for  $dia_m$ :  $dia_0 = \lfloor c/2 \rfloor$ ;  $dia_m = dia_{m-1} + \lfloor d/2 \rfloor$ ,  $m \geq 1$ .

**Theorem 5** For odd  $d$ ,  $dia_m = \lfloor d/2 \rfloor m + \lfloor c/2 \rfloor$ .

*Proof* We prove the theorem by induction on  $m$ . For  $m \geq 1$ , we have that  $dia_m = dia_{m-1} + \lfloor d/2 \rfloor = \lfloor d/2 \rfloor(m-1) + \lfloor c/2 \rfloor + \lfloor d/2 \rfloor = \lfloor d/2 \rfloor m + \lfloor c/2 \rfloor$ . This completes the proof.  $\square$

*CASE B*  $d$  is even.

By Lemma 6 (b), we have that  $T_i = dist_m(di + d/2)$ . Since the node  $di + d/2$  has no nearest town, by Lemma 4 (b), we have that  $dist_m(di + d/2) = \min\{dist_m(di), dist_m(d(i+1))\} + d/2 = \min\{dist_{m-1}(i), dist_{m-1}(i+1)\} + d/2$ . Thus, we have that  $dia_m = \max_{0 \leq i < cd^{m-1}} T_i = \max_{0 \leq i < cd^{m-1}} \min\{dist_{m-1}(i), dist_{m-1}(i+1)\} + d/2$ . Let  $S_{m-1}$  be the max-of-min term in the last equation, that is,  $S_{m-1} = \max_{0 \leq i < cd^{m-1}} \min\{dist_{m-1}(i), dist_{m-1}(i+1)\}$ .

**Lemma 9**  $S_{m-1} = dia_{m-1} - \alpha_{m-1}$ , where

$$\alpha_m = \begin{cases} 0, & \text{if } G(cd^m, d) \text{ has a node pair } (i, i+1) \text{ such that } dist_m(i) = dist_m(i+1) = dia_m; \\ 1, & \text{otherwise.} \end{cases}$$

*Proof* We know that  $S_{m-1} \leq dia_{m-1}$ . We have that  $S_{m-1} \geq dia_{m-1} - 1$  since the difference between  $dist_{m-1}(i)$  and  $dist_{m-1}(i+1)$  is at most one for all  $i$ ,  $0 \leq i < cd^{m-1}$ . If  $\alpha_{m-1} = 0$ , there exists a vertex  $v$  such that  $\min\{dist_{m-1}(v), dist_{m-1}(v+1)\} = dia_{m-1}$ ; otherwise, for every vertex  $i$ ,  $\min\{dist_{m-1}(i), dist_{m-1}(i+1)\} \leq dia_{m-1} - 1$ . Thus, we have the lemma.  $\square$

Now, we have a recursive formula for  $dia_m$ :  $dia_0 = \lfloor c/2 \rfloor$ ;  $dia_m = dia_{m-1} + d/2 - \alpha_{m-1}$ ,  $m \geq 1$ . The term  $\alpha_{m-1}$  depends only on the parity of  $c$  and  $d$  as shown in the following lemma.

**Lemma 10**  $\alpha_m = 1$  if and only if both  $c$  and  $m$  are either odd or even.

*Proof*  $\alpha_0 = 0$  if  $c$  is odd; otherwise,  $\alpha_0 = 1$ . It is sufficient to show that  $\alpha_m = 1 - \alpha_{m-1}$  for all  $m \geq 1$ . Firstly, we assume that  $\alpha_{m-1} = 0$  and show that  $\alpha_m = 1$ . For every vertex  $v = di + j$  such that  $0 \leq i < cd^{m-1}$ ,  $0 \leq j \neq d/2 < d$ , we have that  $dist_m(v) = \min\{dist_m(di) + j, dist_m(d(i+1)) + (d-j)\} \leq dia_{m-1} + \min\{j, d-j\} < dia_{m-1} + d/2 = dia_m$ . Thus, there is no vertex  $v$  such that  $dist_m(v) = dist_m(v+1) = dia_m$ , and we have  $\alpha_m = 1$ . Secondly, we assume that  $\alpha_{m-1} = 1$  and show that  $\alpha_m = 0$ . There is  $i$  such that  $dist_{m-1}(i) = dia_{m-1}$ . We know that  $dist_{m-1}(i+1) = dia_{m-1} - 1$ . We show that  $dist_m(di + d/2 - 1) = dist_m(di + d/2) = dia_m$ . We have that  $dist_m(di + d/2 - 1) = dist_m(di) + d/2 - 1 = dia_{m-1} + d/2 - 1 = dia_m$ , and that  $dist_m(di + d/2) = dist_m(d(i+1)) + d/2 = dia_{m-1} - 1 + d/2 = dia_m$ . Thus,  $\alpha_m = 0$ . We have the lemma.  $\square$

**Theorem 6** For even  $d$ ,

$$dia_m = \begin{cases} \lfloor \frac{d-1}{2}m \rfloor + \lfloor c/2 \rfloor, & \text{if } c \text{ is even;} \\ \lceil \frac{d-1}{2}m \rceil + \lfloor c/2 \rfloor, & \text{if } c \text{ is odd.} \end{cases}$$

*Proof* The proof is done by induction on  $m$  for cases depending on the parities of  $c$  and  $m$ . We know that  $dia_m = dia_{m-1} + d/2 - \alpha_{m-1}$  for  $m \geq 1$ .

*Case 1* both  $c$  and  $m$  are even.

We have that  $dia_m = dia_{m-1} + d/2 = \lfloor \frac{d-1}{2}(m-1) \rfloor + \lfloor c/2 \rfloor + d/2 = \lfloor \frac{d-1}{2}(m-1) + d/2 \rfloor + \lfloor c/2 \rfloor = \lfloor \frac{d-1}{2}m \rfloor + \lfloor c/2 \rfloor$ .

*Case 2*  $c$  is even and  $m$  is odd.

We have that  $dia_m = dia_{m-1} + d/2 - 1 = \lfloor \frac{d-1}{2}(m-1) \rfloor + \lfloor c/2 \rfloor + d/2 - 1 = \lfloor \frac{d-1}{2}(m-1) + d/2 - 1 \rfloor + \lfloor c/2 \rfloor = \lfloor \frac{d-1}{2}m \rfloor + \lfloor c/2 \rfloor$ .

*Case 3* both  $c$  and  $m$  are odd.

We have that  $dia_m = dia_{m-1} + d/2 = \lceil \frac{d-1}{2}(m-1) \rceil + \lfloor c/2 \rfloor + d/2 = \lceil \frac{d-1}{2}(m-1) + d/2 \rceil + \lfloor c/2 \rfloor = \lceil \frac{d-1}{2}m \rceil + \lfloor c/2 \rfloor$ .

*Case 4*  $c$  is odd and  $m$  is even.

We have that  $dia_m = dia_{m-1} + d/2 - 1 = \lceil \frac{d-1}{2}(m-1) \rceil + \lfloor c/2 \rfloor + d/2 - 1 = \lceil \frac{d-1}{2}(m-1) + d/2 - 1 \rceil + \lfloor c/2 \rfloor = \lceil \frac{d-1}{2}m \rceil + \lfloor c/2 \rfloor$ .  $\square$

Fault diameter of a graph  $G$  is the maximum diameter of any graph obtained from  $G$  by removing  $\kappa(G) - 1$  or less vertices. It was shown that the fault diameter of  $G(2^m, 2^k)$  with  $k \geq 2$  (resp. with  $k = 1$ ) is no more than the diameter of  $G(2^m, 2^k)$  plus  $2^{k-1}$  (resp. 2) [22], and that the fault diameter of  $G(2^m, 4)$  is no more than the diameter of  $G(2^m, 4)$  plus 1 for  $m \geq 5$  [16]. The fault diameter of  $G(cd^m, d)$  is not known in the literature.

### 4.3 Mean internode distance

Mean internode distance is the average distance between two distinct nodes, which is an indicator of average message delay under the uniform message distribution. The total distance  $td_m$  from node 0 to all other nodes in  $G(cd^m, d)$  is defined to be  $\sum_{0 \leq v < cd^m} dist_m(v)$ . The mean internode distance  $mid_m$  of  $G(cd^m, d)$  is  $td_m / (cd^m - 1)$  since  $G(cd^m, d)$  is node symmetric. The rest of this section is devoted to calculating  $td_m$ .

**Lemma 11**  $td_0 = \lfloor c^2/4 \rfloor$ .

*Proof* Let  $td_0^k$  be the total distance when  $c = k$ . It holds that  $td_0^1 = 0$  and  $td_0^2 = 1$ . Let  $\Delta = td_0^k - td_0^{k-2}$  for  $k \geq 3$ . We have that  $\Delta = \frac{k-1}{2} + \frac{k-1}{2} = k-1$  for odd  $k$ , and that  $\Delta = \frac{k}{2} + \frac{k-2}{2} = k-1$  for even  $k$ . Thus,  $td_0^k = td_0^{k-2} + \Delta = \lfloor (k-2)^2/4 \rfloor + (k-1) = \lfloor k^2/4 \rfloor$ .  $\square$

For  $m \geq 1$ , we have that  $td_m = \sum_{0 \leq v < cd^m} dist_m(v) = \sum_{0 \leq i < cd^{m-1}} \sum_{0 \leq j < d} dist_m(di + j) = \sum_{0 \leq j < d} \sum_{0 \leq i < cd^{m-1}} dist_m(di + j)$ . Let  $U_j = \sum_{0 \leq i < cd^{m-1}} dist_m(di + j)$ , and thus  $td_m = \sum_{0 \leq j < d} U_j$ . We have two cases depending on the parity of  $d$ .

*CASE A*  $d$  is odd.

By Lemma 5, it holds that  $U_j = \sum_{0 \leq i < cd^{m-1}} \{dist_{m-1}(i) + j\} = td_{m-1} + j \cdot cd^{m-1}$  for  $0 \leq j \leq \lfloor d/2 \rfloor$ , and that  $U_j = \sum_{0 \leq i < cd^{m-1}} \{dist_{m-1}(i+1) + (d-j)\} = td_{m-1} + (d-j) \cdot cd^{m-1}$  for  $\lfloor d/2 \rfloor \leq j < d$ . Thus, the total distance  $td_m$  can be expressed in a recursive formula:  $td_m = \sum_{0 \leq j < d} U_j = \sum_{0 \leq j \leq \lfloor d/2 \rfloor} U_j + \sum_{\lfloor d/2 \rfloor \leq j < d} U_j = \{(\lfloor d/2 \rfloor + 1) \cdot td_{m-1} + cd^{m-1} \sum_{0 \leq j \leq \lfloor d/2 \rfloor} j\} + \{(d - \lfloor d/2 \rfloor) \cdot td_{m-1} + cd^{m-1} \sum_{\lfloor d/2 \rfloor \leq j < d} (d-j)\} = d \cdot td_{m-1} + 2cd^{m-1} \sum_{1 \leq j \leq \lfloor d/2 \rfloor} j = d \cdot td_{m-1} + \frac{d^2-1}{4} cd^{m-1}$ .

**Theorem 7** For odd  $d$ ,  $td_m = cd^m (\frac{d^2-1}{4d} m + \lfloor c^2/4 \rfloor / c)$ .

*Proof* We prove the theorem by induction on  $m$ . By Lemma 11,  $td_0 = \lfloor c^2/4 \rfloor$ . For  $m \geq 1$ ,  $td_m = d \cdot td_{m-1} + \frac{d^2-1}{4} cd^{m-1} = d \{cd^{m-1} (\frac{d^2-1}{4d} (m-1) + \lfloor c^2/4 \rfloor / c)\} + \frac{d^2-1}{4} cd^{m-1} = cd^m (\frac{d^2-1}{4d} m + \lfloor c^2/4 \rfloor / c)$ .  $\square$

*CASE B*  $d$  is even.

We analyze  $U_j$  based on Lemmas 4 (b) and 5. Note that node  $di + j$  has a nearest town except only when  $j = d/2$ . Thus, we have that  $U_j = \sum_{0 \leq i < cd^{m-1}} \{dist_{m-1}(i) + j\} = td_{m-1} + j \cdot cd^{m-1}$  for

$0 \leq j \leq d/2 - 1$ , and that  $U_j = \sum_{0 \leq i < cd^{m-1}} \{dist_{m-1}(i+1) + (d-j)\} = td_{m-1} + (d-j) \cdot cd^{m-1}$  for  $d/2 - 1 \leq j < d$ . When  $j = d/2$ ,  $U_j = \sum_{0 \leq i < cd^{m-1}} \{\min\{dist_{m-1}(i), dist_{m-1}(i+1)\} + d/2\} = \sum_{0 \leq i < cd^{m-1}} \min\{dist_{m-1}(i), dist_{m-1}(i+1)\} + (d/2) \cdot cd^{m-1}$ . Let  $S'_{m-1}$  be the sum-of-min term in the last equation, that is,  $S'_{m-1} = \sum_{0 \leq i < cd^{m-1}} \min\{dist_{m-1}(i), dist_{m-1}(i+1)\}$ .

We introduce  $\beta_m$  which is the number of node pairs  $(v, v+1)$  in  $G(cd^m, d)$  such that  $dist_m(v) = dist_m(v+1)$ , and discuss relationship between  $S'_{m-1}$  and  $\beta_m$  later. We can see, by Lemmas 5 and 6 (b), that the equality  $dist_m(di+(d/2-1)) = dist_m(di+d/2)$  holds only when  $dist_m(di)+1 = dist_m(d(i+1))$ , and that  $dist_m(di+d/2) = dist_m(di+(d/2+1))$  only when  $dist_m(di) = dist_m(d(i+1)) + 1$ . That is, a pair of towns  $di$  and  $d(i+1)$  such that  $dist_m(di) \neq dist_m(d(i+1))$  contributes one to  $\beta_m$ . Thus, we have that  $\beta_m = cd^{m-1} - \beta_{m-1}$  for  $m \geq 1$ ;  $\beta_0 = 0$  for even  $c$ , and  $\beta_0 = 1$  for odd  $c$ .

**Lemma 12**  $S'_{m-1} = td_{m-1} - \beta_m/2$ .

*Proof* We let  $S''_{m-1} = \sum_{0 \leq i < cd^{m-1}} \max\{dist_{m-1}(i), dist_{m-1}(i+1)\}$ . To the sum  $S'_{m-1} + S''_{m-1}$ ,  $i$  and  $i+1$  contribute  $dist_{m-1}(i)$  and  $dist_{m-1}(i+1)$ , for all  $i$ ,  $0 \leq i < cd^{m-1}$ . Thus, we have that  $S'_{m-1} + S''_{m-1} = \sum_{0 \leq i < cd^{m-1}} \{dist_{m-1}(i) + dist_{m-1}(i+1)\} = 2 \cdot td_{m-1}$ . To the difference  $S''_{m-1} - S'_{m-1}$ ,  $i$  and  $i+1$  contribute one only when  $dist_{m-1}(i) \neq dist_{m-1}(i+1)$ . Thus,  $S''_{m-1} - S'_{m-1} = cd^{m-1} - \beta_{m-1}$ , which is equal to  $\beta_m$ . Combining them, we have that  $S'_{m-1} = td_{m-1} - \beta_m/2$ .  $\square$

**Lemma 13**  $\beta_m = \frac{1}{d+1}cd^m - (-1)^m(\frac{c}{d+1} - \beta_0)$ .

*Proof* By induction on  $m$ . The equation holds for  $m = 0$ . Since  $\beta_m = cd^{m-1} - \beta_{m-1}$  for  $m \geq 1$ , we have that  $\beta_m = cd^{m-1} - \{\frac{1}{d+1}cd^{m-1} - (-1)^{m-1}(\frac{c}{d+1} - \beta_0)\} = (1 - \frac{1}{d+1})cd^{m-1} + (-1)^{m-1}(\frac{c}{d+1} - \beta_0) = \frac{1}{d+1}cd^m - (-1)^m(\frac{c}{d+1} - \beta_0)$ .  $\square$

We return to the total distance  $td_m$ . We have that  $td_m = \sum_{0 \leq j < d} U_j = \sum_{0 \leq j \leq d/2-1} U_j + \sum_{d/2+1 \leq j < d} U_j + U_{d/2} = \sum_{0 \leq j \leq d/2-1} \{td_{m-1} + j \cdot cd^{m-1}\} + \sum_{d/2+1 \leq j < d} \{td_{m-1} + (d-j) \cdot cd^{m-1}\} + \{S'_{m-1} + (d/2) \cdot cd^{m-1}\} = d \cdot td_{m-1} + (2 \sum_{1 \leq j \leq d/2-1} j + d/2) \cdot cd^{m-1} - \beta_m/2 = d \cdot td_{m-1} + (d^2/4)cd^{m-1} - \beta_m/2$ . Thus, we get a recursive formula for  $td_m$ :  $td_m = d \cdot td_{m-1} + (d^2/4)cd^{m-1} - \frac{1}{2}\{\frac{1}{d+1}cd^m - (-1)^m(\frac{c}{d+1} - \beta_0)\} = d \cdot td_{m-1} + d^m \frac{c}{2}(\frac{d}{2} - \frac{1}{d+1}) + (-1)^m \frac{1}{2}(\frac{c}{d+1} - \beta_0)$ .

**Theorem 8** For even  $d$ ,  $td_m = d^m \{\frac{c}{2}(\frac{d}{2} - \frac{1}{d+1})m + [c^2/4] - \frac{1}{2(d+1)}(\frac{c}{d+1} - \beta_0)\} + (-1)^m \frac{1}{2(d+1)}(\frac{c}{d+1} - \beta_0)$ .

*Proof* The proof is by induction on  $m$ .  $td_0 = [c^2/4]$  as we want. For  $m \geq 1$ , we have that  $td_m = d \cdot td_{m-1} + d^m \frac{c}{2}(\frac{d}{2} - \frac{1}{d+1}) + (-1)^m \frac{1}{2}(\frac{c}{d+1} - \beta_0)$   
 $= d[d^{m-1} \{\frac{c}{2}(\frac{d}{2} - \frac{1}{d+1})(m-1) + [c^2/4] - \frac{1}{2(d+1)}(\frac{c}{d+1} - \beta_0)\} + (-1)^{m-1} \frac{1}{2(d+1)}(\frac{c}{d+1} - \beta_0)]$   
 $+ d^m \frac{c}{2}(\frac{d}{2} - \frac{1}{d+1}) + (-1)^m \frac{1}{2}(\frac{c}{d+1} - \beta_0)$   
 $= d^m \{\frac{c}{2}(\frac{d}{2} - \frac{1}{d+1})m + [c^2/4] - \frac{1}{2(d+1)}(\frac{c}{d+1} - \beta_0)\} + (-1)^{m-1} \frac{d}{2(d+1)}(\frac{c}{d+1} - \beta_0) + (-1)^m \frac{1}{2}(\frac{c}{d+1} - \beta_0)$   
 $= d^m \{\frac{c}{2}(\frac{d}{2} - \frac{1}{d+1})m + [c^2/4] - \frac{1}{2(d+1)}(\frac{c}{d+1} - \beta_0)\} + (-1)^m (\frac{c}{d+1} - \beta_0)(\frac{1}{2} - \frac{d}{2(d+1)})$   
 $= d^m \{\frac{c}{2}(\frac{d}{2} - \frac{1}{d+1})m + [c^2/4] - \frac{1}{2(d+1)}(\frac{c}{d+1} - \beta_0)\} + (-1)^m \frac{1}{2(d+1)}(\frac{c}{d+1} - \beta_0)$ .

This completes the proof.  $\square$



#### 4.4 Node visit ratio and edge visit ratio

Each time a node sends a message to another node in a network, the message must cross some communication links and pass through intermediate nodes before reaching its destination. If the probability that all possible source-destination pairs exchange messages is known, the number of visits to each node and communication link by an average message can be calculated. The number of visits to a node (resp. an edge) by an average message is called *visit ratio* of the node (resp. the edge). *Node visit ratio* (resp. *edge visit ratio*) is the maximum of the visit ratios over all nodes (resp. edges) in the network, and can be used to locate the bottleneck nodes (resp. edges) that limit the performance of the network. Under the uniform message distribution, we analyze node visit ratio  $nvr_m$  and edge visit ratio  $evr_m$  of the shortest path routing algorithm in  $G(cd^m, d)$  presented in Section 3.

Node visit ratio  $nvr_m$  can be calculated easily using the fact that  $G(cd^m, d)$  is node symmetric. A message from  $v$  to  $w$  contributes one to the visit count of each node in the path between  $v$  and  $w$  (including  $v$  and  $w$ ), and thus we have that  $nvr_m$  is  $(mid_m + 1)/cd^m$ .

**Theorem 9**  $nvr_m = \{td_m/(cd^m - 1) + 1\}/cd^m$ .

Now, we consider edge visit ratio  $evr_m$ . We denote by  $tv_m(e)$  the number of messages visiting the edge  $e$  among  $cd^m - 1$  messages to 0 from all nodes other than 0, and by  $tv_m(d^i)$  the sum of  $tv_m(e)$  for every edge  $e$  of jump  $d^i$ . Employing the fact that every edge pair  $(v, v + d^i)$  and  $(w, w + d^i)$  is similar, we can see that  $evr_m$  is the maximum of  $\overline{tv}_m(d^i)/(cd^m - 1)$ , where  $\overline{tv}_m(d^i)$  is the average number of messages crossing edge  $e$  of jump  $d^i$ , that is,  $\overline{tv}_m(d^i) = tv_m(d^i)/E_i$ , where  $E_i$  is the number of edges of jump  $d^i$ .  $E_i = cd^m/2$  if and only if  $d^i = cd^m/2$ .

$$E_i = \begin{cases} 0 & \text{if } c = 1 \text{ and } i = m; \\ cd^m/2 & \text{if either } c = 1, d = 2, \text{ and } i = m - 1 \text{ or } c = 2 \text{ and } i = m; \\ cd^m & \text{otherwise.} \end{cases}$$

To analyze  $tv_m(d^i)$ , we assume that every node (including node 0) has one message to 0 in  $G(cd^m, d)$ . The message on 0 does not affect the edge visit ratio. Remember that the routing algorithm sends messages along the smallest jump first. Consider the situation that every message is sent via all edges of jump  $d^j$  such that  $0 \leq j < i$ , and waits for delivery in a node which is a multiple of  $d^i$ . We denote by  $\theta(kd^i, i - 1)$  the number of messages waiting for delivery in node  $kd^i$ ,  $0 \leq k < cd^{m-i}$ . Here,  $\sum_{0 \leq k < cd^{m-i}} \theta(kd^i, i - 1)$  is always  $cd^m$ . We consider  $\theta(kd^i, i - 1)$ , and then discuss  $tv_m(d^i)$ . By assumption,  $\theta(kd^0, -1) = 1$  for all  $0 \leq k < cd^m$ . To compute  $\theta(kd^i, i - 1)$ , routing is considered on the subgraph induced by the multiples of  $d^{i-1}$  which is isomorphic to  $G(cd^{m-(i-1)}, d)$ .

**Lemma 14** For odd  $d$ ,  $\theta(kd^i, i - 1) = d^i$  for all  $0 \leq i \leq m$ ,  $0 \leq k < cd^{m-i}$ .

*Proof* We show the lemma by induction on  $i$ . For  $i = 0$ ,  $\theta(kd^0, -1) = d^0$ . The node  $kd^i$  receives messages from  $(kd + j)d^{i-1}$  for all  $-\lfloor d/2 \rfloor \leq j \leq \lfloor d/2 \rfloor$ . Thus, we have that  $\theta(kd^i, i-1) = \sum_{-\lfloor d/2 \rfloor \leq j \leq \lfloor d/2 \rfloor} \theta((kd + j)d^{i-1}, i-2) = \sum_{-\lfloor d/2 \rfloor \leq j \leq \lfloor d/2 \rfloor} d^{i-1} = d^i$ .  $\square$

**Lemma 15** For even  $d$  and  $0 \leq i < m$ ,

$$\theta(kd^i, i-1) = \begin{cases} d^i + D_{i-1} & \text{if } k \bmod d = 0; \\ d^i - D_{i-1} & \text{if } k \bmod d = d/2; \\ d^i & \text{otherwise.} \end{cases}$$

where  $D_j = d^j - D_{j-1}$ ;  $D_{-1} = 0$ .

*Proof*  $D_j$  can be rewritten as  $d^j - d^{j-1} + d^{j-2} \dots + (-1)^j d^0$ . We prove the lemma by induction on  $i$ . For  $i = 0$ ,  $\theta(kd^0, -1) = d^0$ . The node  $kd^i$  receives messages from  $(kd + j)d^{i-1}$  for all  $-(d/2 - 1) \leq j \leq d/2 - 1$ .  $kd^i$  may receive messages from  $(kd - d/2)d^{i-1}$  or  $(kd + d/2)d^{i-1}$  according to Lemma 7 (b). We have the following:

$$\theta(kd^i, i-1) = \begin{cases} \sum_{-d/2 \leq j \leq d/2} \theta((kd + j)d^{i-1}, i-2) & \text{if } k \bmod d = 0; \\ \sum_{-d/2 < j < d/2} \theta((kd + j)d^{i-1}, i-2) & \text{if } k \bmod d = d/2; \\ \sum_{-d/2 < j \leq d/2} \theta((kd + j)d^{i-1}, i-2) & \text{if } 1 \leq k \bmod d \leq d/2 - 1; \\ \sum_{-d/2 \leq j < d/2} \theta((kd + j)d^{i-1}, i-2) & \text{if } d/2 + 1 \leq k \bmod d \leq d - 1. \end{cases}$$

When  $k \bmod d = 0$ , we have that  $\theta(kd^i, i-1) = \sum_{-d/2 \leq j \leq d/2} \theta(jd^{i-1}, i-2) = d \cdot d^{i-1} + (d^{i-1} - D_{i-2}) = d^i + D_{i-1}$ . For  $k = d/2$ ,  $\theta(kd^i, i-1) = d \cdot d^{i-1} - (d^{i-1} - D_{i-2}) = d^i - D_{i-1}$ . When  $k \neq 0, d/2$ , we have that  $\theta(kd^i, i-1) = d^i$ . Thus, we have the theorem.  $\square$

**Lemma 16** For even  $d$ ,  $\theta(kd^m, m-1) = d^m$  if  $c = 1$ . When  $c \geq 2$ ,

$$\theta(kd^m, m-1) = \begin{cases} d^m + D_{m-1} & \text{if } k = 0; \\ d^m - D_{m-1} & \text{if } k = \lceil c/2 \rceil; \\ d^m & \text{otherwise.} \end{cases}$$

*Proof* When  $c = 1$ ,  $k$  must be 0 and  $\theta(kd^m, m-1) = d^m$ . For  $c \geq 2$ , we have the following based on Lemma 7 (a). Here, we have no assumption on the parity of  $c$ .

$$\theta(kd^m, m-1) = \begin{cases} \sum_{-d/2 \leq j \leq d/2} \theta((kd + j)d^{m-1}, m-2) & \text{if } k = 0; \\ \sum_{-d/2 < j < d/2} \theta((kd + j)d^{m-1}, m-2) & \text{if } k = \lceil c/2 \rceil; \\ \sum_{-d/2 < j \leq d/2} \theta((kd + j)d^{m-1}, m-2) & \text{if } 1 \leq k \leq \lceil c/2 \rceil - 1; \\ \sum_{-d/2 \leq j < d/2} \theta((kd + j)d^{m-1}, m-2) & \text{if } \lceil c/2 \rceil + 1 \leq k \leq c - 1. \end{cases}$$

For  $k = 0$ ,  $\theta(kd^m, m-1) = \sum_{-d/2 \leq j \leq d/2} \theta(jd^{m-1}, m-2) = d \cdot d^{m-1} + (d^{m-1} - D_{m-2}) = d^m + D_{m-1}$  by Lemma 15. For  $k = \lceil c/2 \rceil$ , we have that  $\theta(kd^m, m-1) = d \cdot d^{m-1} - (d^{m-1} - D_{m-2}) = d^m - D_{m-1}$ . For the rest cases,  $\theta(kd^m, m-1) = d^m$ . This completes the proof.  $\square$

Let us consider  $tv_m(d^i)$ . Note that  $tv_m(d^m)$  is not defined when  $c = 1$ , since there is no edge of jump  $d^m$ . It holds that  $0 < D_j/d^j \leq 1$  and  $D_j/d^j = \frac{d}{d+1}\{1 - (-\frac{1}{d})^{j+1}\}$  for all  $j \geq 0$ .

**Lemma 17**

$$tv_m(d^i) = \begin{cases} \lfloor c^2/4 \rfloor & \text{if } i = 0 \text{ and } m = 0; \\ cd^{m-1} \lfloor d^2/4 \rfloor & \text{if } i = 0 \text{ and } m \geq 1; \\ cd^{m-1} \lfloor d^2/4 \rfloor & \text{if } 1 \leq i < m \text{ and } d \text{ odd}; \\ cd^{m-1} \{ \lfloor d^2/4 \rfloor - (1/2)D_{i-1}/d^{i-1} \} & \text{if } 1 \leq i < m \text{ and } d \text{ even}; \\ d^m \lfloor c^2/4 \rfloor & \text{if } i = m \text{ and } d \text{ odd}. \\ d^m \lfloor c^2/4 \rfloor - \lfloor c/2 \rfloor D_{m-1} & \text{if } i = m \text{ and } d \text{ even}. \end{cases}$$

*Proof* We have that  $tv_0(d^0) = \sum_{0 < j < c} \min\{j, c - j\}$ . It holds that  $\sum_{0 < j < c} \min\{j, c - j\} = 2 \sum_{1 \leq j \leq (c-1)/2} j = \lfloor c^2/4 \rfloor$  for odd  $c$ , and that  $\sum_{0 < j < c} \min\{j, c - j\} = 2 \sum_{1 \leq j \leq (c/2-1)} j + c/2 = \lfloor c^2/4 \rfloor$  for even  $c$ . Thus,  $tv_0(d^0) = \lfloor c^2/4 \rfloor$ . For  $m \geq 1$ , we have that  $td_m(d^0) = \sum_{0 \leq k < cd^{m-1}} \sum_{0 < j < d} \theta((kd + j), -1) \cdot \min\{j, d - j\} = cd^{m-1} \sum_{0 < j < d} \min\{j, d - j\} = cd^{m-1} \lfloor d^2/4 \rfloor$ . Now, we consider the case of  $1 \leq i < m$ . We have that  $td_m(d^i) = \sum_{0 \leq k < cd^{m-i-1}} \sum_{0 < j < d} \theta((kd + j)d^i, i - 1) \cdot \min\{j, d - j\} = cd^{m-i-1} \sum_{0 < j < d} \theta(jd^i, i - 1) \cdot \min\{j, d - j\}$ . For odd  $d$ , by Lemma 14, we have that  $td_m(d^i) = cd^{m-i-1} \sum_{0 < j < d} d^i \cdot \min\{j, d - j\} = cd^{m-1} \lfloor d^2/4 \rfloor$ . For even  $d$ , by Lemma 15, we have that  $tv_m(d^i) = cd^{m-i-1} \{2 \sum_{1 \leq j \leq d/2-1} d^i \cdot j + (d^i - D_{i-1}) \cdot d/2\} = cd^{m-1} \{ \lfloor d^2/4 \rfloor - (1/2)D_{i-1}/d^{i-1} \}$ . For the last case of  $i = m$  ( $c \geq 2$ ), we have that  $tv_m(d^m) = \sum_{0 < k < c} \theta(kd^m, m - 1) \cdot \min\{k, c - k\}$ . For odd  $d$ , by Lemma 14,  $tv_m(d^m) = \sum_{0 < k < c} d^m \cdot \min\{k, c - k\} = d^m \lfloor c^2/4 \rfloor$ . For even  $d$ , by Lemma 16,  $tv_m(d^m) = \sum_{0 < k < c, k \neq \lfloor c/2 \rfloor} d^m \cdot \min\{j, c - j\} + (d^m - D_{m-1}) \cdot \lfloor c/2 \rfloor = d^m \lfloor c^2/4 \rfloor - \lfloor c/2 \rfloor D_{m-1}$ .  $\square$

**Lemma 18** (a) For  $1 \leq i < m$ ,  $tv_m(d^i) \leq tv_m(d^0)$ .

(b) For  $m \geq 1$  and  $c \geq 2$ ,  $tv_m(d^m) \leq tv_m(d^0)$ .

(c) For even  $d$  and  $1 \leq i < m$ ,  $tv_m(d^i) - tv_m(d^{i-1}) = (-1)^i cd^{m-i}/2$ .

*Proof* A proof of (a) is immediate from Lemma 17 since  $D_{i-1}/d^{i-1}$  is always positive. We have that  $td_m(d^0) - td_m(d^m) = d^{m-1} \{c \lfloor d^2/4 \rfloor - d \lfloor c^2/4 \rfloor\} > 0$  for odd  $d$  and  $td_m(d^0) - td_m(d^m) = d^{m-1} \{c \lfloor d^2/4 \rfloor - d \lfloor c^2/4 \rfloor\} + \lfloor c/2 \rfloor D_{m-1} > 0$  for even  $d$ , since  $c \lfloor d^2/4 \rfloor - d \lfloor c^2/4 \rfloor \geq c(d^2 - 1)/4 - d(c^2/4) = \{cd(d - c) - c\}/4 \geq (cd - c)/4 > 0$ . For (c), we have that  $tv_m(d^i) - tv_m(d^{i-1}) = -(1/2)cd^{m-1}(D_{i-1}/d^{i-1} - D_{i-2}/d^{i-2})$ . Here,  $D_{i-1}/d^{i-1} - D_{i-2}/d^{i-2} = (D_{i-1} - dD_{i-2})/d^{i-1} = (-1)^{i-1}/d^{i-1}$ . This completes the proof.  $\square$

By using Lemmas 17 and 18, we can calculate edge visit ratio  $evr_m$ .

**Theorem 10**

$$evr_m = \begin{cases} \{\lfloor c^2/4 \rfloor / c\} / (cd^m - 1) & \text{if } m = 0; \\ \frac{1}{3} \{2 + (-\frac{1}{2})^{m-1}\} / (cd^m - 1) & \text{if } c = 1, d = 2, \text{ and } m \geq 2; \\ 1 / (cd^m - 1) & \text{if either } c = 1, d = 2, \text{ and } m = 1 \text{ or } c = 2 \text{ and } d = 3; \\ \{\lfloor d^2/4 \rfloor / d\} / (cd^m - 1) & \text{otherwise.} \end{cases}$$

*Proof* Let  $T$  be the maximum of  $\overline{tv}_m(d^i) = tv_m(d^i)/E_i$  over all possible  $i$ . Then we have that  $evr_m = T/(cd^m - 1)$ . When  $m = 0$ , we have that  $T = tv_m(d^0)/cd^0 = \lfloor c^2/4 \rfloor / c$ . We assume that  $m \geq 1$ . Note that  $E_i = 0$  if  $c = 1$  and  $i = m$ ;  $E_i = cd^m/2$  if either  $c = 1$ ,  $d = 2$ , and  $i = m - 1$  or  $c = 2$  and  $i = m$ ; otherwise,  $E_i = cd^m$ .

*Case 1*  $c = 1$ : We have no edge of jump  $d^m$ .

*Case 1.1*  $d$  odd:

By Lemma 18 (a),  $T = \max_{0 \leq i \leq m-1} tv_m(d^i)/cd^m = tv_m(d^0)/cd^m = cd^{m-1} \lfloor d^2/4 \rfloor / cd^m = \lfloor d^2/4 \rfloor / d$ .

*Case 1.2*  $d$  even:

*Case 1.2.1*  $d = 2$ :  $E_{m-1} = cd^m/2$ .

When  $m = 1$ ,  $T = tv_m(d^0)/E_0 = cd^{m-1} \lfloor d^2/4 \rfloor / (cd^m/2) = 1$ . For  $m \geq 2$ , we have that  $\max_{0 \leq i \leq m-2} tv_m(d^i)/cd^m = tv_m(d^0)/cd^m = \lfloor d^2/4 \rfloor / d = 1/2$ , and that  $tv_m(d^{m-1})/E_{m-1} = cd^{m-1} \{ \lfloor d^2/4 \rfloor - (1/2)D_{m-2}/d^{m-2} \} / (cd^m/2) = 1 - (1/2)D_{m-2}/d^{m-2} \geq 1/2$  since it holds that  $0 \leq D_{m-2}/d^{m-2} \leq 1$ . Thus, we have that  $T = 1 - (1/2)D_{m-2}/d^{m-2}$  and can show that  $T = \{2 + (-1/2)^{m-1}\}/3$ .

*Case 1.2.2*  $d \neq 2$ :

We have that  $T = \max_{0 \leq i \leq m-1} tv_m(d^i)/cd^m = tv_m(d^0)/cd^m = \lfloor d^2/4 \rfloor / d$ .

*Case 2*  $c = 2$ :  $E_m = cd^m/2$ .

*Case 2.1*  $d$  odd:

We have that  $\max_{0 \leq i \leq m-1} tv_m(d^i)/cd^m = tv_m(d^0)/cd^m = \lfloor d^2/4 \rfloor / d$ , and that  $tv_m(d^m)/(cd^m/2) = d^m \lfloor c^2/4 \rfloor / (cd^m/2) = (2/c) \lfloor c^2/4 \rfloor = 1$ . Thus,  $T = \max\{\lfloor d^2/4 \rfloor / d, 1\}$ .  $T = 1$  if  $d = 3$ ; otherwise,  $T = \lfloor d^2/4 \rfloor / d$ .

*Case 2.2*  $d$  even:

We have that  $\max_{0 \leq i \leq m-1} tv_m(d^i)/cd^m = tv_m(d^0)/cd^m = \lfloor d^2/4 \rfloor / d$ , and that  $tv_m(d^m)/(cd^m/2) = \{d^m \lfloor c^2/4 \rfloor - \lfloor c/2 \rfloor D_{m-1}\} / (cd^m/2) = (2/c) \lfloor c^2/4 \rfloor - (2/cd) \lfloor c/2 \rfloor D_{m-1}/d^{m-1} = 1 - (1/d)D_{m-1}/d^{m-1}$ . We can see that  $\lfloor d^2/4 \rfloor / d = d/4 \geq 1$ , and that  $1 - (1/d)D_{m-1}/d^{m-1} = 1 - \frac{1}{d+1} \{1 - (-\frac{1}{d})^m\} \leq 1 - \frac{1}{d}$  since  $0 < 1 - (-\frac{1}{d})^m \leq \frac{d+1}{d}$  for all  $m \geq 1$ . Thus, we have that  $T = \max\{\lfloor d^2/4 \rfloor / d, 1 - (1/d)D_{m-1}/d^{m-1}\} = \lfloor d^2/4 \rfloor / d$ .

*Case 3*  $c \geq 3$ :

We have that  $T = \max_{0 \leq i \leq m} tv_m(d^i)/cd^m = tv_m(d^0)/cd^m = \lfloor d^2/4 \rfloor / d$ . This completes the proof.  $\square$

## 5 Embeddings among $G(2^m, 2^k)$ and $Q_m$

An *embedding* of a (guest) graph  $G$  into a (host) graph  $H$  is a one-to-one mapping  $\phi$  of the vertices of  $G$  into the vertices of  $H$ , combined with a mapping of an edge  $e = (v, w)$  of  $G$  to a path  $\phi(e)$  of  $H$  between  $\phi(v)$  and  $\phi(w)$ . The cost of an embedding  $\phi$  is measured in terms of dilation, congestion, and expansion. The *dilation* of an edge  $e$  in  $G$  under the embedding  $\phi$  is the length of the path  $\phi(e)$ , and the dilation of  $\phi$  is the maximum dilation over all edges in  $G$ . The *congestion* of an edge  $e'$  in  $H$  is the

number of edges  $e$  in  $G$  with  $\phi(e)$  including  $e'$ , and the congestion of  $\phi$  is the maximum congestion over all edges in  $H$ . The *expansion* of  $\phi$  is the ratio of the size of  $G$  to the size of  $H$ .

### 5.1 Embedding of $G(2^m, 2^k)$ into $Q_m$

We present an expansion one embedding  $\phi_m$  of recursive circulant  $G(2^m, 2^k)$  into hypercube  $Q_m$ . The embedding  $\phi_m$  is simple and recursively defined. The node  $\phi_m(v)$  of  $Q_m$  to which a node  $v$  of  $G(2^m, 2^k)$  is mapped is a  $v$ th  $m$ -bit binary reflected Gray code, which is defined as follows:  $\phi_1(0) = 0$  and  $\phi_1(1) = 1$ ;  $\phi_m(v) = \phi_{m-1}(\lfloor v/2 \rfloor)b$ , where  $b = 0$  if  $v \bmod 4$  is either 0 or 3,  $b = 1$  otherwise. The sequence of  $\phi_3(v)$ 's, for example, is (000, 001, 011, 010, 110, 111, 101, 100). The sequence of  $\phi_m(v)$ 's forms a hamiltonian cycle of  $Q_m$ , and we call it the *canonical* cycle of  $Q_m$ .

Let us restrict our attention to the embedding of  $G(2^m, 2)$  into  $Q_m$ . The embedding of  $G(2^m, 2^k)$  into  $Q_m$  can be obtained directly from the embedding of  $G(2^m, 2)$  into  $Q_m$  with the same embedding costs since  $G(2^m, 2^k)$  is a subgraph of  $G(2^m, 2)$ . To define the path  $\phi_m(e)$  of  $Q_m$  for an edge  $e$  of  $G(2^m, 2)$ , it is convenient to represent the embedding  $\phi_m$  in a graphical way.

In the graphical representation of  $\phi_m$ ,  $Q_m$  is drawn in a usual way (see Figure 5 (a) and (b)): small circles for vertices and solid lines for edges of  $Q_m$ . A node  $v$  of  $G(2^m, 2)$  mapped to the node  $\phi_m(v)$  of  $Q_m$  is parenthesized and shown next to  $\phi_m(v)$ . An edge  $e = (v, w)$  of  $G(2^m, 2)$  mapped to the path  $\phi_m(e)$  of  $Q_m$  is drawn in dotted line between  $\phi_m(v)$  and  $\phi_m(w)$ .

The embedding  $\phi_m$  of  $G(2^m, 2)$  into  $Q_m$  can be constructed recursively (see also Figure 5). We denote by  $\phi'_m$  the embedding  $\phi_m$  excluding all the dotted paths mapped from the edges of jump one. That is,  $\phi'_m$  is an embedding of  $G(2^m, 2)$  without edges of jump one into  $Q_m$ . We make two copies  $\phi'_{m-1}$  and concatenate "0" and "1" at the end of vertices in the first and second copy of  $Q_{m-1}$ , respectively. Now they are the vertices of  $Q_m$ . Join by a solid edge between nodes differing only in the last bit position, and rename the parenthesized nodes of  $G(2^m, 2)$  according to  $\phi_m(v)$ .

Observe that the dotted path mapped from an edge of jump  $2^j$  ( $j \geq 1$ ) in  $\phi_{m-1}$  is now the path for an edge of jump  $2^{j+1}$  in  $\phi_m$ . The dotted paths  $\phi_m(e)$  for edges of jump one are drawn on the canonical cycle of  $Q_m$ , and the dotted paths  $\phi_m(e)$  for edges of jump two are drawn in such a way that the congestions of edges on the canonical cycle of each  $Q_{m-1}$  are increased by no more than two and the congestions of edges joining nodes differing in the last bit position are three.

We are ready to define the path  $\phi_m(e)$  of  $Q_m$  to which an edge  $e = (v, w)$  of  $G(2^m, 2)$  is mapped. The path is represented by a sequence of vertices. Assume  $v + 2^i \equiv w \pmod{2^m}$ .

#### Case 1 $i \geq 2$

$\phi_m(e)$  is obtained by concatenating  $b$  at the end of each vertex in the path  $\phi_{m-1}(e')$  of  $Q_{m-1}$ , where  $e' = (\lfloor v/2 \rfloor, \lfloor w/2 \rfloor)$ ,  $b = 0$  if  $v \bmod 4$  is either 0 or 3, and  $b = 1$  otherwise.

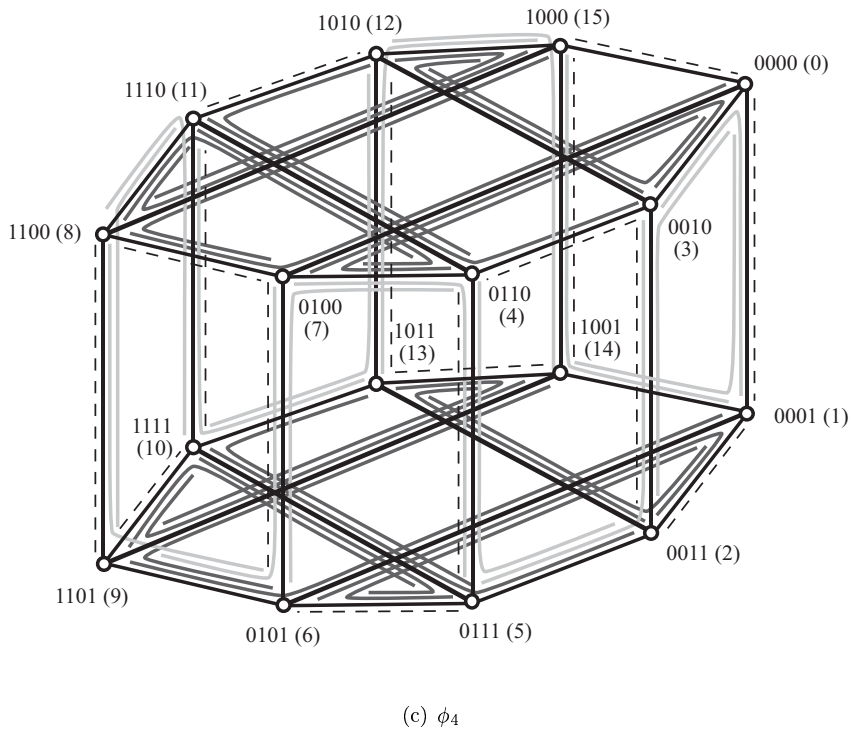
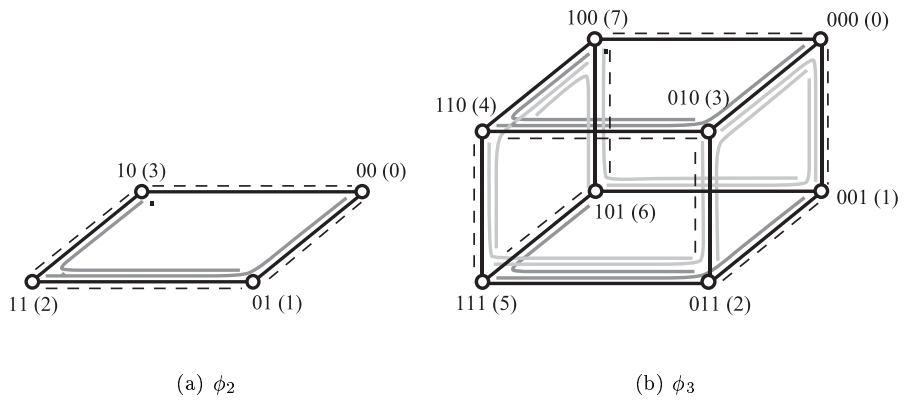

Figure 5: Graphical representation of  $\phi_m$

**Case 2**  $i = 1$

$\phi_m(e)$  is the path of length two passing through the vertex  $\phi_m((v + 3) \bmod 2^m)$  if  $v \bmod 4$  is either 0 or 2, and passing through the vertex  $\phi_m((v - 1) \bmod 2^m)$  otherwise.

**Case 3**  $i = 0$

$\phi_m(e)$  is the path  $\phi_m(v), \phi_m(w)$  of length one.

Now, we consider the costs, dilation and congestion, of the embedding  $\phi_m$  of  $G(2^m, 2)$  into  $Q_m$ . To analyze the costs, we consider the costs of  $\phi'_m$  first.

**Lemma 19** *The embedding  $\phi'_m$  satisfies the two conditions for all  $m$ .*

(a) *The dilation of an edge of jump greater than one is two.*

(b) *The congestion of an edge on the canonical cycle of  $Q_m$  is no more than two, and the congestions of the other edges are no more than four.*

*Proof* We prove the lemma by induction on  $m$ . Observe that two conditions (a) and (b) hold for  $m = 2, 3$  as shown in Figure 5. Assume that the embedding  $\phi'_{m-1}$  satisfies the conditions. The dilation of an edge of jump two is two by the definition of  $\phi_m$ . The dilation of an edge of jump greater than two in  $\phi'_m$  is equal to that of an edge of half jump in  $\phi'_{m-1}$ , thus two. Thus, we have (a). An edge on the canonical cycle of  $Q_m$  is either an edge joining nodes differing in the last bit position (we call it type A edge) or on an canonical cycle of  $Q_{m-1}$  (we call it type B edge). The congestion of type A edge is two by the construction of  $\phi_m$ , and the congestion of type B edge remains two since every dotted path from an edge of jump two passes through no type B edge. The congestion of an edge not on the canonical cycle of  $Q_m$  but on an canonical cycle of  $Q_{m-1}$  is increased by two, still no more than four. The congestions of the other edges remain unchanged. This completes the proof.  $\square$

**Theorem 11**  *$G(2^m, 2)$  can be embedded into  $Q_m$  with dilation two and congestion four.*

*Proof* The dotted paths  $\phi_m(e)$  for edges of jump one are of length one and drawn on the canonical cycle of  $Q_m$ . The dilation of an edge of jump one in  $G(2^m, 2)$  is one, and the congestion of an edge on the canonical cycle is increased by one. Thus, by Lemma 19,  $\phi_m$  is an embedding with dilation two and congestion four.  $\square$

**Corollary 3**  *$G(2^m, 2^k)$  can be embedded into  $Q_m$  with dilation two and congestion four.*

Dilation of the embedding is the best possible for  $k < m$ , since  $G(2^m, 2^k)$  is not a subgraph of  $Q_m$ .  $G(2^m, 2^k)$  has a cycle  $0, 1, \dots, 2^k$  of length  $2^k + 1$ , while  $Q_m$  has no odd length cycle.

## 5.2 Embedding of $Q_m$ into $G(2^m, 2^k)$

We present the embeddings of  $Q_m$  into  $G(2^m, 2^k)$  based on the embeddings of  $Q_k$  into a path graph  $P_{2^k}$ , which has vertices  $\{0, 1, \dots, 2^k - 1\}$  and edges  $\{(v, w) \mid v + 1 = w\}$ . One of the embeddings of  $Q_m$  into  $G(2^m, 2^k)$ , denoted by  $\psi_m^k$ , is an identity mapping. Recall that  $Q_m$  and  $G(2^m, 2^k)$  have the same vertex set. We also employ graphical representations for embedding  $\psi_m^k$ . Here small circles and solid lines are used for representing vertices and edges of  $G(2^m, 2^k)$ , and dotted lines for paths of  $G(2^m, 2^k)$  mapped from edges of  $Q_m$ . For example, see Figure 6.

Under the embedding  $\psi_m^k$ , the vertices of  $Q_m$  with the same least significant  $k$  bits are mapped to the vertices of  $G(2^m, 2^k)$  with the same remainder when divided by  $2^k$ . The dotted path  $\psi_m^k(e)$  in  $G(2^m, 2^k)$  for an edge  $e = (v, w)$  is drawn on the line between  $\psi_m^k(v)$  and  $\psi_m^k(w)$  if  $v$  and  $w$  differ in one of the least significant  $k$  bits; otherwise, the path  $\psi_m^k(e)$  comes from the path  $\psi_{m-k}^k(e')$  in  $G(2^{m-k}, 2^k)$ , where  $e' = (\lfloor v/2^k \rfloor, \lfloor w/2^k \rfloor)$ .

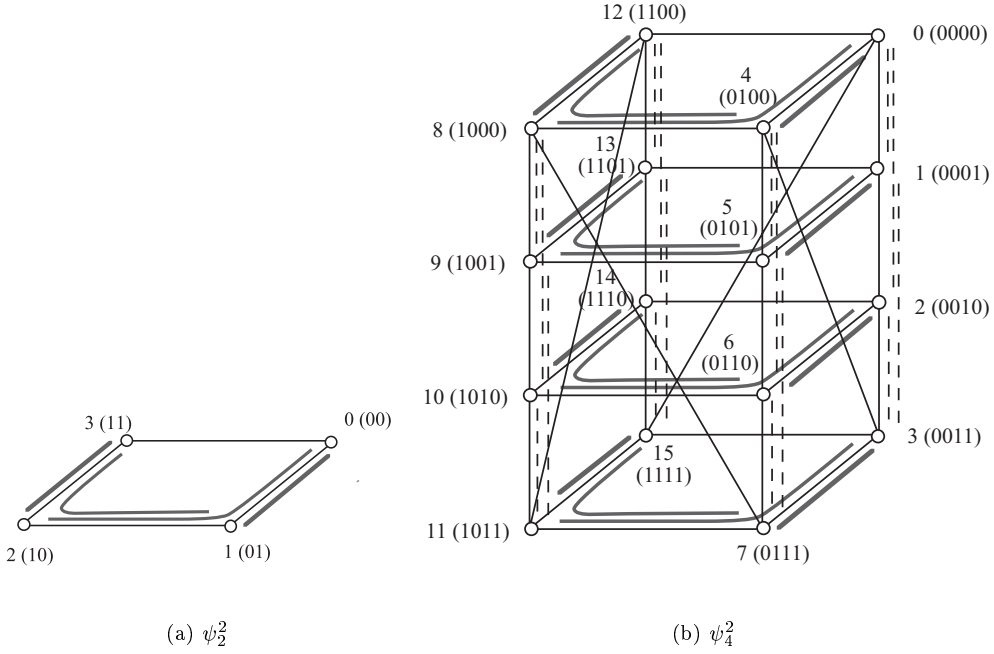

Figure 6: Graphical representation of  $\psi_m^2$

The path  $\psi_m^k(e)$  of  $G(2^m, 2^k)$  for an edge  $e = (v, w)$  of  $Q_m$  is defined in the following. We assume that  $v = b_{m-1} \dots b_{i+1} 0 b_{i-1} \dots b_0$  and  $w = b_{m-1} \dots b_{i+1} 1 b_{i-1} \dots b_0$ ,  $b_j \in \{0, 1\}$ . The path is represented by a sequence of vertices.

**Case 1**  $0 \leq i \leq k - 1$



$\psi_m^k(e)$  is the dotted path  $\psi_m^k(v), \psi_m^k(v+1), \dots, \psi_m^k(w)$  of length  $2^i$ .

**Case 2**  $k+1 \leq i \leq m$

$\psi_m^k(e)$  is the path obtained by multiplying  $2^k$  and adding  $\psi_m^k(v) \bmod 2^k$  for each vertex in the path  $\psi_{m-k}^k(e')$ , where  $e' = (v', w')$ , and  $v'$  and  $w'$  are  $m-k$  bit binary numbers obtained by deleting the least significant  $k$  bits of  $v$  and  $w$ , respectively.

Let us consider the costs of embedding  $\psi_m^k$ . The identity embedding of  $Q_k$  into  $P_{2^k}$  was studied in [12]. It was proved that the embedding has dilation  $2^{k-1}$  and congestion  $\lfloor 2^{k+1}/3 \rfloor$ , and that both congestion and the sum  $2^{2k-1} - 2^{k-1}$  of dilations over all edges are the minimum possible.

**Lemma 20** *The identity embedding of  $Q_k$  into  $P_{2^k}$  has dilation  $2^{k-1}$  and congestion  $\lfloor 2^{k+1}/3 \rfloor$ .*

**Theorem 12**  *$Q_m$  can be embedded into  $G(2^m, 2^k)$  with dilation  $2^{k-1}$  and congestion  $\lfloor 2^{k+1}/3 \rfloor$ .*

*Proof* The dilation (resp. congestion) of  $\psi_m^k$  is the maximum of the dilation (resp. congestion) of  $\psi_{m-k}^k$  and the dilation (resp. congestion) of identity embedding of  $Q_k$  into  $P_{2^k}$ . For  $m' \leq k$ , both dilation and congestion of  $\psi_{m'}^k$  are less than or equal to those of the identity embedding of  $Q_k$  into  $P_{2^k}$ , respectively. Thus, the dilation and congestion of  $\psi_m^k$  are equal to those of the identity embedding of  $Q_k$  into  $P_{2^k}$ , respectively.  $\square$

Insisting on embeddings of  $Q_m$  into  $G(2^m, 2^k)$  such that vertices of  $Q_m$  with the same last  $k$  bits are mapped to vertices of  $G(2^m, 2^k)$  with the same remainder when divided by  $2^k$ , we can reduce dilation of the embedding by employing the optimal dilation embedding of  $Q_k$  into  $P_{2^k}$  in [13]. We can define another embedding  $\psi_m^k$  of  $Q_m$  into  $G(2^m, 2^k)$  in a very similar way to  $\psi_m^k$ . An edge  $(v, w)$  is mapped to the path  $\psi_m^k(e)$  according to the embedding of  $Q_k$  into  $P_{2^k}$  if  $v$  and  $w$  differ in one of the least significant  $k$  bits; otherwise, the path  $\psi_m^k(e)$  comes from the path  $\psi_{m-k}^k(e')$  in  $G(2^{m-k}, 2^k)$ , where  $e' = (\lfloor v/2^k \rfloor, \lfloor w/2^k \rfloor)$ . Detailed description of the embedding  $\psi_m^k$  is omitted.

**Lemma 21**  *$Q_k$  can be embedded into  $P_{2^k}$  with dilation  $\sum_{i=0}^{k-1} \binom{i}{\lfloor i/2 \rfloor}$  and congestion  $\lceil \frac{k}{2} \rceil \binom{k}{\lfloor k/2 \rfloor}$ .*

*Proof* We employ the algorithm in [13] for embedding  $Q_k$  into  $P_{2^k}$  with the optimal dilation  $\sum_{i=0}^{k-1} \binom{i}{\lfloor i/2 \rfloor}$  to analyze the congestion of the embedding. The algorithm chooses any vertex and maps it to 0; having  $l$  vertices mapped to  $\{0, 1, \dots, l-1\}$ , it maps to  $l$  from any vertex adjacent to the earliest mapped vertex as possible. For our purpose, we assume that in the first step, the algorithm chooses the vertex 0 in  $Q_k$ . We denote by  $W_i$  the subset of vertices in  $Q_k$  whose binary representation has  $i$  1's. We observe that every vertex in  $W_i$  is chosen before any vertex in  $W_{i+1}$ , and that the vertices in  $W_i$  are mapped to  $W_i' = \{v_i, v_i+1, \dots, v_i+|W_i|-1\}$  where  $v_i = \sum_{0 \leq j < i} |W_j|$ . Among  $k$  edges incident to a vertex mapped to  $v_i+j$ ,  $i$  edges have endvertices in  $W_{i-1}$  and the remaining  $k-i$  edges have endvertices in  $W_{i+1}$ . Thus, the congestion of the edge  $(v_i+j-1, v_i+j)$  is equal

to  $i(|W_i| - j) + (k - i)j$ . The maximum congestion  $C_i$  over all edges incident to a vertex in  $W_i'$  is  $\max_{0 \leq j \leq |W_i|} \{i(|W_i| - j) + (k - i)j\} = \max\{i, k - i\}|W_i|$ . Note that  $C_i = \max\{i, k - i\} \binom{k}{i} = C_{k-i}$ . The congestion of the embedding is  $C_{\max} = \max_{0 \leq i \leq k} C_i = \max_{0 \leq i \leq \lfloor k/2 \rfloor} C_i$ . We claim that  $C_{\max} = C_{\lfloor k/2 \rfloor} = \lceil \frac{k}{2} \rceil \binom{k}{\lfloor k/2 \rfloor}$ . For every  $i \leq \lfloor k/2 \rfloor - 1$ , it holds that  $C_{i+1}/C_i = (k - (i + 1))/(i + 1) \geq 1$  since  $\max\{i + 1, k - (i + 1)\} = k - (i + 1)$ ,  $\max\{i, k - i\} = k - i$ , and  $\binom{k}{i+1}/\binom{k}{i} = (k - i)/(i + 1)$ . Thus, we have the claim. This completes the proof.  $\square$

**Theorem 13**  $Q_m$  can be embedded into  $G(2^m, 2^k)$  with dilation  $\sum_{i=0}^{k-1} \binom{i}{\lfloor i/2 \rfloor}$  and congestion  $\lceil \frac{k}{2} \rceil \binom{k}{\lfloor k/2 \rfloor}$ .

*Proof* We can observe that the dilation (resp. congestion) of  $\psi_m^k$  is the maximum of the dilation (resp. congestion) of  $\psi_{m-k}^k$  and the dilation (resp. congestion) of the embedding of  $Q_k$  into  $P_{2^k}$ , and thus we have the theorem by Lemma 21.  $\square$

### 5.3 Embedding of $G(2^m, 2)$ into $G(2^m, 2^k)$

We present an embedding of  $G(2^m, 2)$  into  $G(2^m, 2^k)$ . The embedding is an identity mapping, that is, a vertex  $v$  of  $G(2^m, 2)$  is mapped to the same vertex  $v$  of  $G(2^m, 2^k)$ . An edge  $e = (v, w)$  of  $G(2^m, 2)$  satisfying  $v + 2^i \equiv w \pmod{2^m}$  is mapped to the dotted path  $v, v + 1, v + 2, \dots, w$  between  $v$  and  $w$  on the hamiltonian cycle consisting of edges of jump one if  $i < k$ . Here, the additions are performed modulo  $2^m$ . Otherwise, the path comes from the embedding of  $G(2^{m-k}, 2)$  into  $G(2^{m-k}, 2^k)$ . Detailed description of the embedding is omitted.

**Theorem 14**  $G(2^m, 2)$  can be embedded into  $G(2^m, 2^k)$  with dilation  $2^{k-1}$  and congestion  $2^k - 1$ .

*Proof* Let us consider the embedding of all edges of jump less than  $2^k$  into the hamiltonian cycle of length  $2^m$ . The dilation of the embedding is obviously  $2^{k-1}$ . All edges of jump  $2^i$  contribute  $2^i$  to the congestion of an edge, and thus the congestion of the embedding is  $\sum_{0 \leq j \leq k-1} 2^j = 2^k - 1$ . We can observe that the dilation (resp. congestion) of the embedding of  $G(2^m, 2)$  into  $G(2^m, 2^k)$  is the maximum of  $2^{k-1}$  (resp.  $2^k - 1$ ) and the dilation (resp. congestion) of the embedding of  $G(2^{m-k}, 2)$  into  $G(2^{m-k}, 2^k)$ . Combining this with the fact that the dilation (resp. congestion) of the embedding of  $G(2^{m'}, 2)$  into  $G(2^{m'}, 2^k)$  with  $m' \leq k$  is less than or equal to  $2^{k-1}$  (resp.  $2^k - 1$ ), we can prove the theorem.  $\square$

### 5.4 Relationship among $G(2^m, 2)$ , $G(2^m, 4)$ , and $Q_m$

Let us discuss some interesting relationships between recursive circulants and hypercubes, especially among  $G(2^m, 2)$ ,  $G(2^m, 4)$ , and  $Q_m$ . The relationships are presented in Figure 7. Here an arrow with weights from a graph  $G$  to  $H$  is an embedding of  $G$  into  $H$  and their associated costs: dilation and congestion in sequence. Both  $G(2^m, 4)$  and  $Q_m$  are subgraphs of  $G(2^m, 2)$ .  $G(2^m, 2)$  can be embedded

into  $Q_m$  with dilation two and congestion four by Theorem 11.  $G(2^m, 4)$  also can be embedded into  $Q_m$  with the same costs. And  $Q_m$  can be embedded into  $G(2^m, 4)$  with dilation two and congestion two by Theorem 12. The embedding of  $G(2^m, 2)$  into  $G(2^m, 4)$  is due to the Theorem 14.

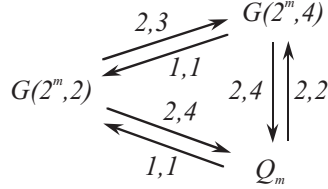

Figure 7: Relationship among  $G(2^m, 2)$ ,  $G(2^m, 4)$ , and  $Q_m$  in their embeddings

Now, let us consider optimality of the embedding costs given in Figure 7. It is easy to check that dilations of all the given embeddings are optimal. Congestion of the embedding of  $Q_m$  into  $G(2^m, 4)$  is optimal for  $m \geq 3$  since they are non-isomorphic graphs with the same number of vertices and edges.

Optimality of congestion of the embedding of  $G(2^m, 2)$  into  $G(2^m, 4)$  can be shown by a simple counting argument. Among  $(2m - 1)2^{m-1}$  edges of  $G(2^m, 2)$ , at most  $m2^{m-1}$  edges are mapped to dotted paths of length one and at least  $(m - 1)2^{m-1}$  edges are mapped to paths of length two or more. The sum of lengths of the dotted paths is at least  $(3m - 2)2^{m-1}$ . Even though they are distributed over all edges of  $G(2^m, 4)$ , congestion of the embedding is at least  $\lceil (3m - 2)2^{m-1} / m2^{m-1} \rceil = \lceil (3m - 2)/m \rceil$ , which is greater than or equal to three for all  $m \geq 3$ . Thus, the embedding of  $G(2^m, 2)$  into  $G(2^m, 4)$  has an optimal congestion for  $m \geq 3$ .

It is not known whether or not congestions of the embedding of  $G(2^m, 2)$  and  $G(2^m, 4)$  into  $Q_m$  are optimal. If we insist on embeddings by the binary reflected Gray code, congestion four is not avoidable by a counting argument.

## 6 Concluding Remarks

In this paper, recursive circulants were proposed as an interconnection structure for multicomputer networks. Recursive circulants are node symmetric and have some strong hamiltonian properties:  $G(N, d)$  is either hamiltonian connected or bipartite and bihamiltonian connected, and  $G(cd^m, d)$  is hamiltonian decomposable. We developed a shortest path routing algorithm without routing table in  $G(cd^m, d)$ , and analyzed several important network metrics of  $G(cd^m, d)$  such as connectivity, diameter, mean internode distance, and visit ratio (under the uniform message distribution). As shown in Table 1,  $G(2^m, 4)$  achieves noticeable improvements compared with hypercube  $Q_m$  in diameter, mean internode distance, and node visit ratio. Connectivity and edge connectivity, edge visit ratio of  $G(2^m, 4)$  are equal to those of  $Q_m$ , respectively.  $G(2^m, 4)$  has a simple shortest path routing algorithm

and a simple recursive broadcasting algorithm.

Table 1: Comparison of  $G(2^m, 4)$  with  $Q_m$

|                 |                                 | $G(2^m, 4)$                   | $Q_m$                        |
|-----------------|---------------------------------|-------------------------------|------------------------------|
| number of nodes |                                 | $2^m$                         | $2^m$                        |
| degree          |                                 | $m$                           | $m$                          |
| symmetry        | node-                           | yes                           | yes                          |
|                 | edge-                           | no                            | yes                          |
| hamiltonicity   | hamiltonian connected           | yes                           | bihamiltonian connected      |
|                 | hamiltonian decomposition       | yes                           | yes                          |
| connectivity    | node-                           | $m$                           | $m$                          |
|                 | edge-                           | $m$                           | $m$                          |
| distance        | diameter                        | $\lceil (3m-1)/4 \rceil$      | $m$                          |
|                 | mean internode distance         | approx. $(9/20)m$             | approx. $(1/2)m$             |
| visit ratio     | node-                           | approx. $\{(9/20)m + 1\}/2^m$ | approx. $\{(1/2)m + 1\}/2^m$ |
|                 | edge-                           | $1/(2^m - 1)$                 | $1/(2^m - 1)$                |
| subgraph        | cycle of length $l$             | every $l \geq 4$              | every even $l \geq 4$        |
|                 | complete binary tree            | yes                           | no                           |
|                 | binomial tree                   | yes                           | yes                          |
| graph invariant | chromatic number, $m \geq 3$    | 3                             | 2                            |
|                 | independence number, $m \geq 3$ | $(3/8)2^m$                    | $(1/2)2^m$                   |

We presented an embedding of  $G(2^m, 2^k)$  into  $Q_m$  based on the binary reflected Gray code with dilation two and congestion four, and also gave embeddings of  $Q_m$  into  $G(2^m, 2^k)$  based on embeddings of  $Q_k$  into  $P_{2^k}$  with either dilation  $2^{k-1}$  and congestion  $\lceil 2^{k+1}/3 \rceil$  or dilation  $\sum_{i=0}^{k-1} \binom{i}{\lfloor i/2 \rfloor}$  and congestion  $\lceil \frac{k}{2} \rceil \binom{k}{\lfloor k/2 \rfloor}$ . All of the embeddings presented in this paper have an optimal expansion. To study embeddings into  $Q_m$  and  $G(2^m, 2^k)$ , it is worthwhile investigating embeddings into  $G(2^m, 2)$ . Embedding of an arbitrary binary tree into  $Q_m$  with dilation two is one of the long standing open questions [4, 26, 27]. Related to the open question, we pose an open problem whether or not every binary tree with  $2^m$  nodes or less is a subtree of  $G(2^m, 2)$ . If our open problem has a positive answer, the question also has a positive one, but the converse is not true in general.

**Acknowledgement** This work was partially supported by the Korean Ministry of Science and Technology under Contract No. NN09020 and NN10730. Prof. D. F. Hsu in Fordham University suggested the term “recursive circulant”. The authors would like to thank profs. Hee-Chul Kim,

Sung Kwon Kim, and Hyeong-Seok Lim for their help and the anonymous referee for improving the presentation of this paper.

## References

- [1] S. B. Akers and B. Krishnamurthy, "On group graphs and their fault tolerance," *IEEE Trans. Computers*, vol. 36, pp. 885-888, Jul. 1987.
- [2] B. W. Arden and H. Lee, "Analysis of chordal ring network," *IEEE Trans. Computers*, vol. 30, pp. 291-295, Apr. 1981.
- [3] L. Banachowski, A. Kreczmar, and W. Rytter, *Analysis of Algorithms and Data Structures*, Addison-Wesley Publishing Company, Seoul, pp. 143-162, 1991.
- [4] S. N. Bhatt, F. R. K. Chung, F. T. Leighton, and A. L. Rosenberg, "Efficient embeddings of trees in hypercubes," *SIAM J. Comput.*, vol. 21, pp. 151-162, Feb. 1992.
- [5] F. Boesch and A. Felzer, "A general class of invulnerable graphs," *Networks*, vol. 2, pp. 261-283, 1972.
- [6] C. C. Chen and N. F. Quimpo, "On strongly hamiltonian abelian group graphs," in *Australian Conference on Combinatorial Mathematics (Lecture Notes in Mathematics #884)*, pp. 23-34, 1980.
- [7] D. Z. Du and F. K. Hwang, "Generalized de Bruijn digraphs," *Networks*, vol. 18, pp. 27-38, 1988.
- [8] J. A. Ellis, "Embedding rectangular grids into square grids," *IEEE Trans. Comput.*, vol. 40, pp. 46-52, Jan. 1991.
- [9] A.-H. Esfahanian, L. M. Ni, and B. E. Sagan, "The twisted N-cube with application to multiprocessing," *IEEE Trans. Computers*, vol. 40, no. 1, pp. 88-93, Jan. 1991.
- [10] A. M. Farley, "Minimal broadcast networks," *Networks*, vol. 9, pp. 313-332, 1979.
- [11] G. Gauyacq, C. Micheneau, and A. Raspaud, "Routing in recursive circulants: edge forwarding index and hamiltonian decomposition," in *Proc. 24th International Workshop on Graph-Theoretic Concepts in Computer Science WG'98 (LNCS #1517)*, Smolenice Castle, Slovak, pp. 227-241, 1998.
- [12] L. H. Harper, "Optimal assignments of numbers to vertices," *J. Soc. Industrial Appl. Math.*, vol. 12, pp. 131-135, Mar. 1964.

- [13] L. H. Harper, "Optimal numberings and isoperimetric problems on graphs," *J. Combin. Theory*, vol. 1, pp. 385-393, 1966.
- [14] K. Hwang and F. A. Briggs, *Computer Architecture and Parallel Processing*, 4th printing, McGraw-Hill International Editions, New York, 1988.
- [15] S.-W. Jung, S.-Y. Kim, J.-H. Park, and K.-Y. Chwa, "Connectivities of recursive circulant graphs," in *Proc. 19th KISS Spring Conference*, pp. 591-594, 1992(in Korean).
- [16] H.-C. Kim, S.-B. Kim, and K.-Y. Chwa, "Fault diameter of recursive circulants," in *Proc. 21th KISS Fall Conference*, pp. 663-666, 1994(in Korean).
- [17] S.-Y. Kim, S.-O Sul, and K. Y. Chwa, "Embeddings of pyramids into recursive circulants," *J. Korea Information Science Society*, vol. 24, pp. 232-239, 1997 (in Korean).
- [18] H.-S. Lim, J.-H. Park, and K. Y. Chwa, "Embedding trees in recursive circulants," *Discrete Applied Mathematics*, vol. 69, pp. 83-93, 1996.
- [19] C. Micheneau, *Graphes Récurifs Circulants, Communication Vagabondes et Simulation*, PhD Thesis, LaBRI, Université Bordeaux I, France, 1996.
- [20] J.-H. Park, "Hamiltonian decomposition of recursive circulants," in *Proc. 9th International Symposium on Algorithms and Computation ISAAC'98 (LNCS #1533)*, Taejon, Korea, pp. 297-306, 1998.
- [21] J.-H. Park and K. Y. Chwa, "Recursive circulant: a new topology for multicomputer networks (extended abstract)," in *Proc. Int. Symp. Parallel Architectures, Algorithms and Networks IS-PAN'94*, Kanazawa, Japan, pp. 73-80, Dec. 1994.
- [22] J.-H. Park and K.-Y. Chwa, "Disjoint paths of bounded length in recursive circulants  $G(2^m, 2^k)$ ," in *Proc. 25th KISS Spring Conference*, pp. 685-687, 1998(in Korean).
- [23] D. A. Reed and R. M. Fujimoto, *Multicomputer Networks: Message-Based Parallel Processing*, The MIT Press, 1987.
- [24] A. L. Rosenberg, "Issues in the study of graph embeddings," *Lecture Notes in Computer Science*, vol. 100, Springer-Verlag, New York, pp. 150-176, 1981.
- [25] N.-F. Tzeng and S. Wei, "Enhanced hypercubes," *IEEE Trans. Computers*, vol. 40, pp. 284-294, Mar. 1991.
- [26] A. Wagner, "Embedding arbitrary binary trees in a hypercube," *J. Parallel Distrib. Comput.*, vol. 7, pp. 503-520, 1989.

- [27] A. Y. Wu, "Embedding of tree networks into hypercubes," *J. Parallel Distrib. Comput.*, vol. 2, pp. 238-249, 1985.